

OPERATION, PARTS AND **SAFETY** MANUAL



SIGNODE®

VFX-9/13

TENSION-WELD®
STRAPPING TOOL

IMPORTANT!
DO NOT DESTROY

It is the customer's responsibility to
have all operators and servicemen
read and understand this manual.

Contact your local Signode representative
for additional copies of this manual.

READ ALL INSTRUCTIONS BEFORE OPERATING THIS SIGNODE PRODUCT

WARNING

READ THESE INSTRUCTIONS CAREFULLY.

FAILURE TO FOLLOW THESE INSTRUCTIONS CAN RESULT IN SEVERE PERSONAL INJURY.

GENERAL SAFETY CONSIDERATIONS

1. STRAP BREAKAGE HAZARD.

Improper operation of the tool or sharp corners on the load can result in strap breakage during tensioning, which could result in the following:

- A sudden loss of balance causing you to fall.
- Both tool and strap flying violently towards your face.

Failure to place the strap properly around the load or an unstable or shifted load could result in a sudden loss of strap tension during tensioning. This could result in a sudden loss of balance causing you to fall.

Read the tool's operating instructions. If the load corners are sharp use edge protectors. Place the strap correctly around a properly positioned load.

- Positioning yourself in-line with the strap, during tensioning and sealing, can result in severe personal injury from flying strap or tool. When tensioning or sealing, position yourself to one side of the strap and keep all bystanders away.
- Using strap not recommended for this tensioner can result in strap breakage during tensioning. Use the correct Signode products for your application.

2. TRAINING.

This tool must not be used by persons not properly trained in its use. Be certain that you receive proper training from your employer. If you have any questions contact your Signode Representative.

3. EYE INJURY HAZARD.

Failure to wear safety glasses with side shields can result in severe eye injury or blindness. Always wear safety glasses with side shields which conform to ANSI Standard Z87.1 or EN 166.



4. FALL HAZARD.

Maintaining improper footing and/or balance when operating the tool can cause you to fall. Do not use the tool when you are in an awkward position.

5. CUT HAZARD.

Handling strap or sharp parts could result in cut hands or fingers. Wear protective gloves.



WARNING

6. TOOL CARE.

Take good care of the tool. Inspect and clean it daily, lubricate it weekly and adjust when necessary. Replace any worn or broken parts.

7. WORK AREA.

Keep work areas uncluttered and well lighted.

Several types of strap can be used with this tool. Use the correct Signode products for your application. If you need help contact your Signode Representative.

SAFETY PROCEDURES FOR TOOL OPERATION

1. Before using this tool, read its Operation and Safety instructions.

- Do not exceed the operating air pressures stated elsewhere in the manual.
- Use Signode's approved filter-regulator-lubricator unit (P-008559).
- Never operate a pneumatic tool with a bottled air or gas source.
- For tension adjustments, follow instructions in this manual. For all other adjustments, repairs or cleaning of the tool, disconnect air supply.
- This tool is a Tension Weld® type sealer. A properly made joint will appear as shown in the illustration. If the joint does not appear as shown, then the operator must proceed as follows:



A. Insure that the tools operating instructions are being followed before applying another strap.

B. Cut the strap off and apply another.

If the joint still does not appear as shown, then inspect the tool for worn and/or damaged parts. Replace tool parts as needed. **NEVER HANDLE OR SHIP ANY LOAD WITH IMPROPERLY FORMED JOINTS.** Misformed joints may not secure the load and could cause serious injury.

- Tuck strap end back into the dispenser when not in use.

CUTTING TENSIONED STRAP

Use only cutters designed for cutting strap; never use claw hammers, crowbars, chisels, axes or similar tools. Such tools will cause the strap to fly apart with hazardous force. Before using any Signode product, read its Operation and Safety Manual.

TABLE OF CONTENTS

	Page		Page
General Safety Instructions	2	Parts List, Air Motors	22
Specifications	4	Parts List, Tool	24
Pneumatic Information	5	Troubleshooting	26
Operating Instructions	9	Maintenance	30
Adjustments	11	Tool Options	31
Parts Removal and Replacement	14	Declaration of Conformity	35
Air Logic and Diagram	21		

VFX-9/13
Part No. 429276

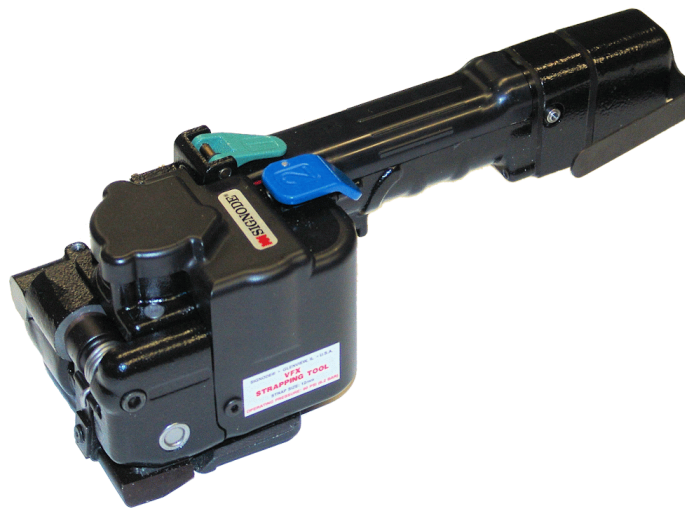

SPECIFICATIONS

MODEL	STRAP		
	TYPE	WIDTH	THICKNESS
VFX-L	{302}, {304}, 306 Dymax {502}, {504}, 506, 508 Dymax	7/16"(10.5mm) 1/2"(12.7mm)	0.017" to 0.029" (.43-.73mm) 0.015" to 0.030" (.38-.76mm)
	{714}, {716}, 718 Contrax {814}, {816}, 818 Contrax	7/16"(10.5mm) 1/2"(12.7mm)	0.019" to 0.030" (.48-.76mm) 0.017" to 0.026" (.43-.66mm)
	{1716}, 1718 Tenax {1816}, 1818, 1822 Tenax	7/16"(10.5mm) 1/2"(12.7mm)	0.021" to 0.024" (.53-.60mm) 0.017" to 0.028" (.43-.71mm)

VFX MAJOR COMPONENTS

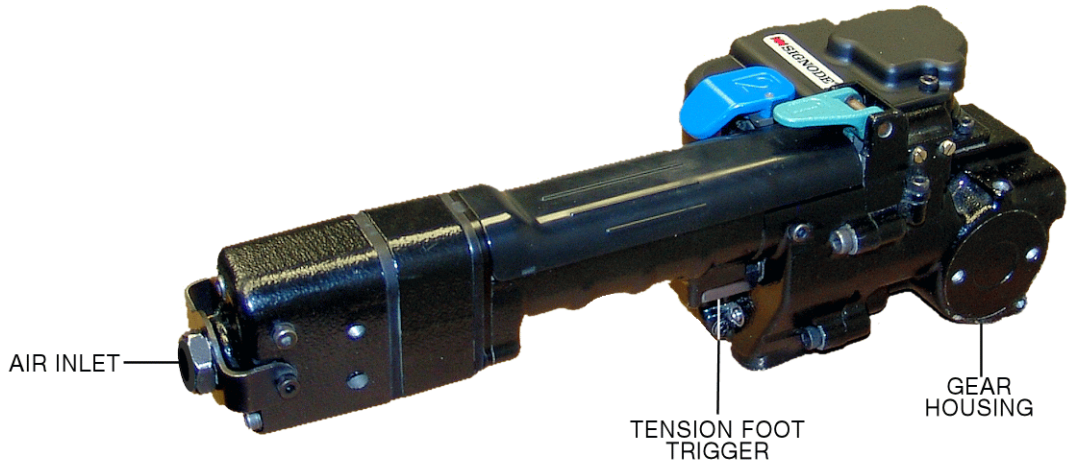
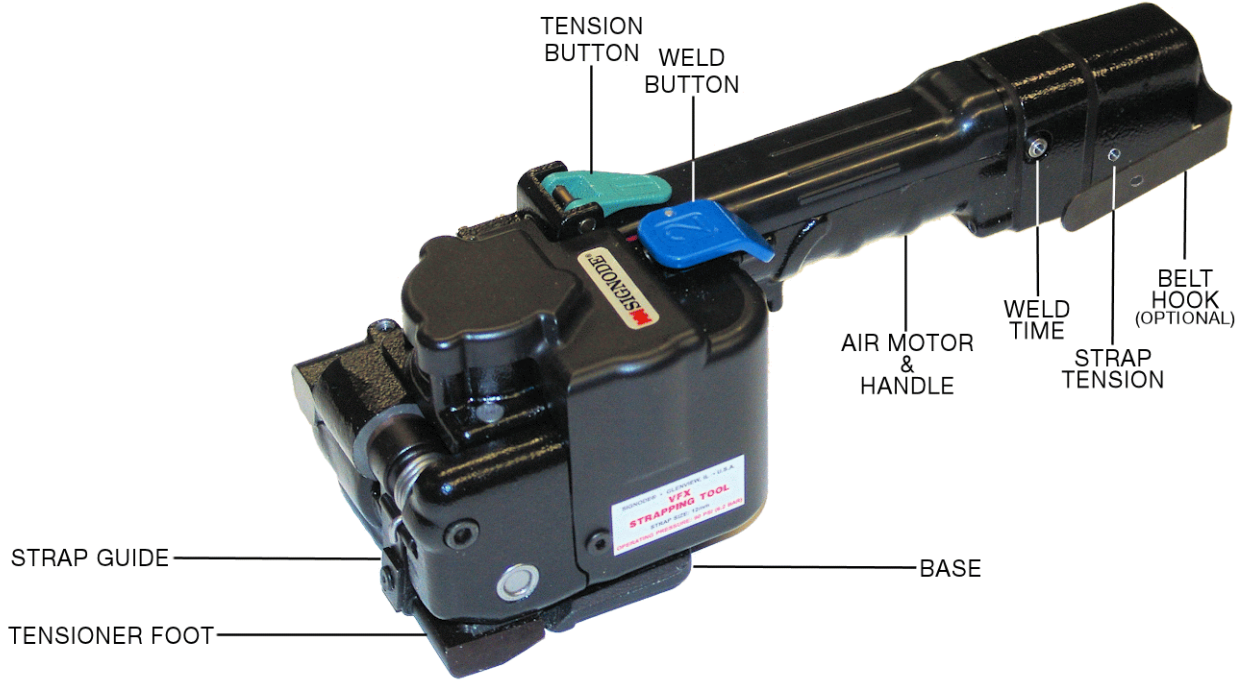

PNEUMATIC INFORMATION

AIR PRESSURE REQUIREMENTS

The VFX tool is designed to operate at an air pressure of 90 psig (6.2 Bar).

AIR PRESSURE VS. PERFORMANCE

The air pressure supplied to the VFX tool must be a minimum of 85 psig (5.7 Bar) If the air supply pressure can be adjusted within a range from 85 psi to 90 psi (5.7 - 6.2 Bar) the VFX tool's performance can be fine tuned to a particular application or operation preferences. Changing the VFX air supply pressure to the tool will directly alter the rate at which the tool will take-up the strap slack and the strap tension. Increasing or decreasing the VFX air supply within the suggested 85 to 90 psig (5.7-6.2 Bar) range will not seriously affect the actual welding portion of the strap cycle. After an initial "Break-In" period, the air motor may become more powerful. If the tool's performance is effected by this increase in performnace, reduce the air motor output by turning the adjustment screw (Key 47 on the Air Motor Assembly) counter-clockwise as required.

AIR SUPPLY INSTALLATION

If compressor has a good dryer unit, use black pickled pipe. When a dryer unit is not installed, use galvanized or copper pipe. To perform reliably, a pneumatic tool requires a continuous source of clean, water-free air at adequate pressure. A Filter-Regulator-Lubricator (FRL) unit must be installed as close to the air tool as possible, preferably within 10 feet (3M). It should be placed in a convenient location where it can easily be drained, adjusted, and filled with oil. The air hose must have at least a 1/2" (12mm) I.D. A quick-connect press-on socket is installed on the stress spring end of the hose for convenient hookup to the air tool.

Filter and lubricator bowls are made of polycarbonate material. Do not install where bowls may be exposed to materials incompatible with polycarbonate. Certain oils, solvents, and chemicals or their fumes can weaken these bowls and possibly cause them to burst. Clean only with warm water. A cut-off valve placed ahead of the filter will be useful when cleaning the filter or replenishing the lubricator.

Signode Pneumatic Accessories:

ITEM	PART NO.
FRL W/ 10' HOSE	429141
FRL W/O HOSE	429130
QUICK-CONNECT SOCKET (LOW FLOW)	429134
QUICK CONNECT PLUG (LOW FLOW) 020704	
QUICK-CONNECT SOCKET (HIGH FLOW)	015294
QUICK CONNECT PLUG (HIGH FLOW)	015293

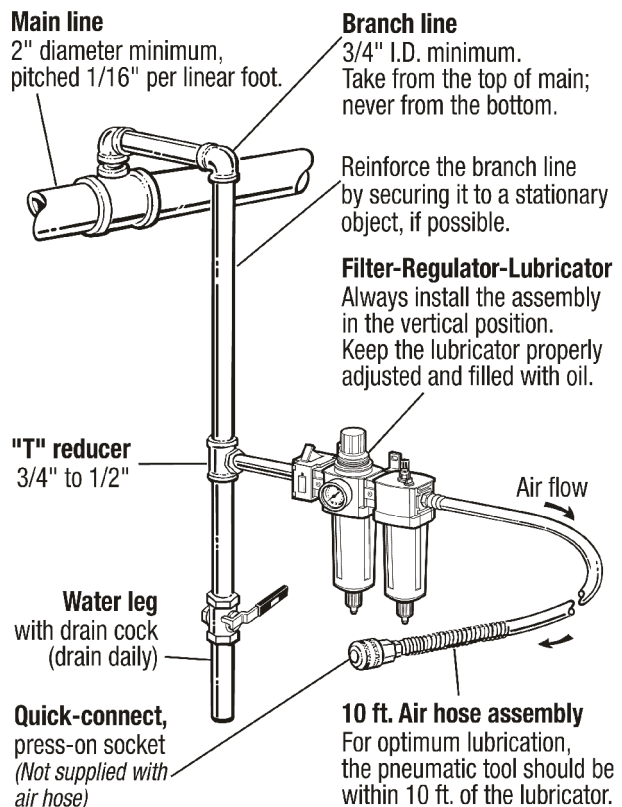

PNEUMATIC INFORMATION, Continued

MOISTURE

Moisture is always present in air lines due to condensation within the lines as the air cools. Steps must be taken to remove this moisture and to keep it from the air tool. This is because water tends to wash away lubricants and cause corrosion, sticking and failure of internal parts.

The main line should be pitched so the far end terminates in a water leg. Branch lines are taken from the top of the main, never off the bottom. Every branch should have a water leg at its lowest point, with a drain cock which is drained daily.

If these precautions are taken and water is still present, an after cooler and a moisture separator are required between the compressor and the air receiver tank. A large air line separator can be installed in the air tool line, but precautions must be taken to insure that it will be drained daily, before the air tool is operated.

Water in air lines is a constant threat to the proper operation of air tool. Even near freezing operating conditions, a good refrigerant type dryer is essential. A good dryer will remove 95% or more of water right at the compressor. The remaining moisture is removed at the water leg in the piping system or in the filter (Part No. 008559).

NOTE: Additional information is available in the Signode publication, "Air Supply Manual" (Part No. 186038). If you have any questions, contact your local Signode Representative.

LUBRICATION

The air motor must be properly lubricated. This is achieved by keeping the air line lubricator filled with oil and correctly adjusted. Without proper lubrication, the motor will become sticky and the tool will give low and erratic tension and be difficult to release from the strap.

Install the lubricator as close to the air tool as possible. The arrow on the lubricator's top surface must point in the direction of air flow. For proper operation, oil must drop through the lubricator sight glass at a rate of 1 to 4 drops per minute. This rate is checked while the air tool is running free. Only 20% of this oil is actually delivered to the tool. The remaining oil drops back into the oil reservoir. The unit is factory set and should require no adjustment. If an adjustment is required, the adjusting screw on top of the lubricator may be turned as marked to reduce or increase the flow of oil.

The correct grade of oil must be used in the lubricator; too heavy an oil will not provide sufficient lubrication and will cause sticking and sluggish operation of the air tool. Recommended oils are any good grade of rust and oxidation inhibiting oil with a viscosity of 80-120 S.U.S. at 100 degrees Fahrenheit. (0.15 to 0.25 cm² /sec. at 38 degrees Celsius), such as:

Non Fluid Oil Co., grade #LS-1236

Signode oil - Part No. 008556

If necessary, use SAE #5 or SAE #10 non-detergent, cut 1 to 1 with kerosene.

NOTE: Some oils contain anti-wear additives which may disable the air motor. Be certain to use recommended oil.

Several drops of lubricator oil added to the inlet of the air motor or into the air line each day will help insure good operation. A noticeable reduction of air motor performance can usually be corrected by squirting a few drops of oil into the air line.

STRAP TENSION

NOTE: Operating air pressure must be set between 85 and 90 psi (5.7-6.2 Bar). With accurately controlled air pressure the tension will be uniform on all straps, provided the operator allows the air motor to stall.

The VFX tool is factory tested to ensure that at least 140 lbs. (530N) of tension is drawn at 90 psig (6.2 Bar).

Strap tension is controlled by turning the adjustment screw (Key 44) as shown, in 1/4 increment turns counter-clockwise to increase strap tension and clockwise to reduce strap tension.

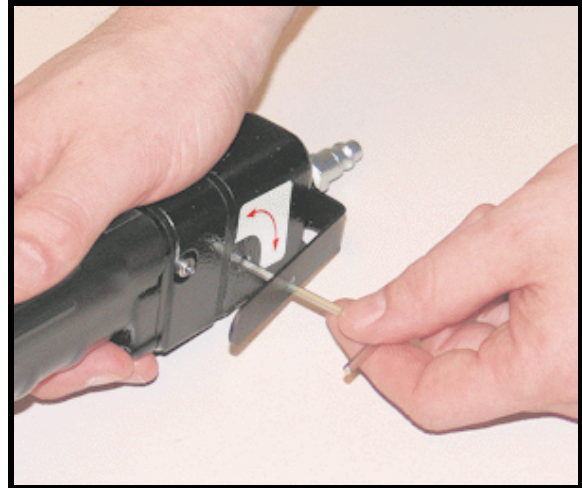

SHOWN WITH OPTIONAL BELT HOOK

! WARNING

Strap breakage hazard.
Strap can break if inlet air pressure to tool exceeds 90 psig (6.2 bar).
Strap breakage can result in severe personal injury.
Maximum operating air pressure is 90 psig (6.2 bar).

AIR CONSUMPTION

Air consumption in cubic feet per minute (cfm) for the VFX can be calculated as follows: $cfm = (a) \times (b) \times (0.37)$

a = Number of straps applied per minute.

b = Number of seconds motor is on per strap during tensioning, from start to deceleration to stall including stall time while making joint.

0.37 = VFX efficiency ratio.

Example Calculation: Peak strapping load is 4 straps/min. so $a = 4$
Air motor is on 5 seconds/strap, so $b = 5$
VFX efficiency ratio is 0.37

$$(a) \times (b) \times (0.37) \rightarrow 4 \times 5 \times 0.37 = 7.4 \text{ cubic ft/min.}$$
$$4 \times 5 \times 0.62 = 12.4 \text{ cubic meters/hr. (12.4M}^3\text{/hr.)}$$

Air pressure is assumed to be 90 psig (6.2 Bar) with recommended size and length of air hose. Volume of air is at room temperature and sea level pressure, or so-called "free air" conditions. For more detailed information about air supply systems refer to Signode manual Part No. 186038.

COLD WEATHER OPERATION

If a tool does not operate satisfactorily in freezing temperatures, certain steps can correct the problem. The following steps can be taken to improve cold weather operation of the tool:

- a. An air line dryer adjacent to the compressor.
- b. Use lubricant recommended by Signode. Signode has tested the use of anti-freezes, none work well in air tool; the tool will gum up when anti-freezes are introduced and will not function properly. The best lubricant for freezing weather is the 1 to 1 oil and kerosene combination.
- c. If possible, run the air supply line to a indoor located Filter-Regulator-Lubricator or relocate the F-R-L to a warmer operating area.

AIR PRESSURE DROP

Confirm air pressure calibration by comparing it to a master gauge placed in-line where the quick disconnect fitting attaches to the tool.



Air pressure at the tool can then be monitored as the tool cycles. Use the following information shown on the chart below for comparing the various minimum air pressures while the VXT-19 tool cycles.

If pressure readings fall below the minimums, inspect your air supply system as well as the tool for worn and/or broken parts. Contact your Signode representative if you have any questions.

AIR LINE PRESSURE MINIMUMS FOR CYCLING Tool

IN-LINE GAUGE READING PSI (BAR)			
SUPPLY/STATIC	TAKE-UP	STALL	WELDING
90 (6.2)	61 (4.1)	80 (5.4)	63 (4.2)

OPERATING INSTRUCTIONS



WARNING Wear safety glasses. Stand to one side of the strap when tensioning. Make sure all bystanders are clear before proceeding.

1. With the dispenser placed behind you, bring the strap over the top and around the package, pulling out excess slack.

NOTE: Do not operate tool without strap, as damage to the tool may occur.

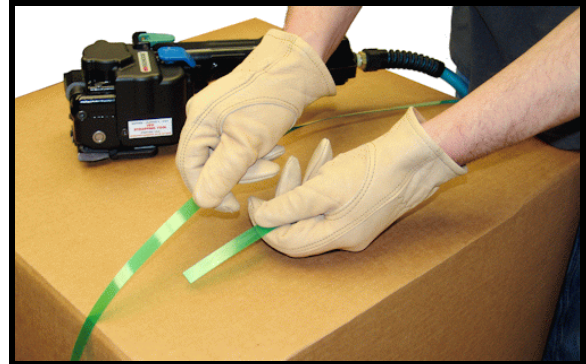

2. Squeeze the Tension Foot trigger (located on the bottom of the tool) to open the Tension Foot.

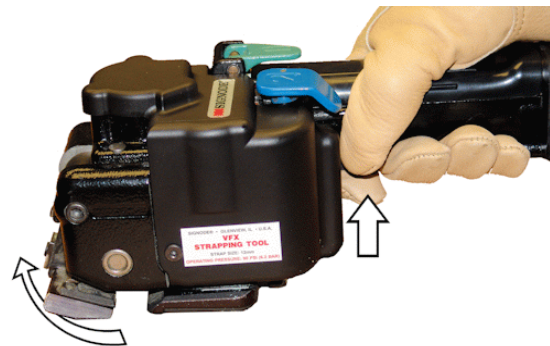

3. Using your left hand, insert the overlapped straps under the feedwheel and welding mechanism. Leave only a short tail ahead of the feedwheel and make sure straps are aligned behind the tool. Do not make a joint over a void area of the package.

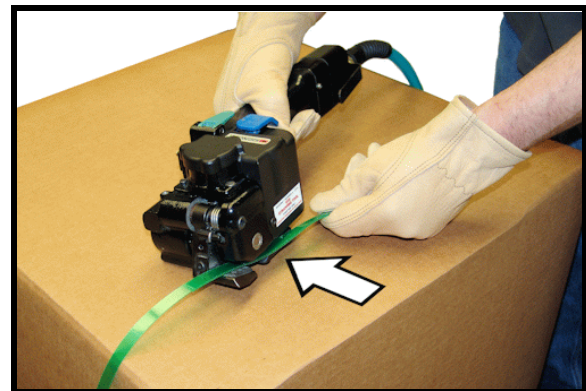

4. Recheck the strap alignment at the rear of the tool and realign if necessary. Release the Tension Foot trigger. While standing to one side of the strap line, press the Tension Button (Green) to tension the strap.

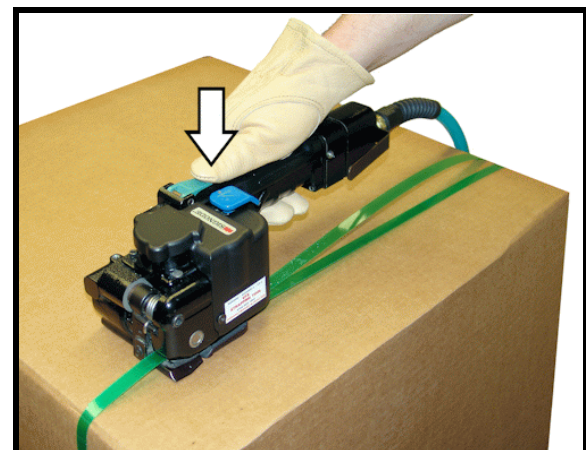

- When the motor stalls, indicating completion of tension, press the Weld Button (Blue) to weld and join the straps together.

NOTE: The Weld Button only need to be pressed once. The button will stay down on it's own.

The internal weld timer is energized. The strap is welded and the supply end of the strap is cut-off. Pull the cut strap away during welding using your left hand.

The tool will continue through the weld cycle and stop automatically. Allow the tool to remain stationary for at least 2 seconds to ensure that the weld is fully cooled.

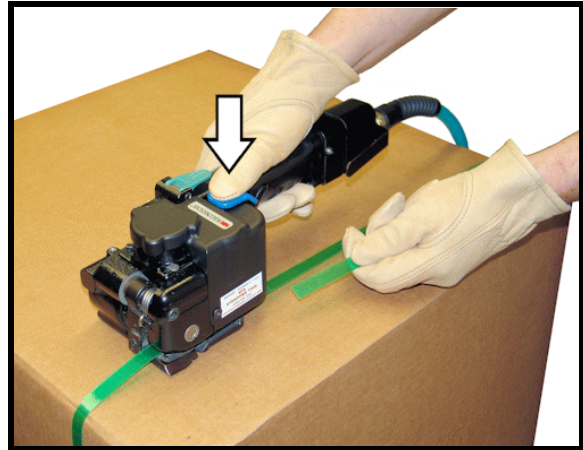

! WARNING

Failure to wait 2 seconds can result in an improperly formed joint which may lead to joint separation.

- Once again, squeeze the Tension Foot trigger to open the strap path and swing the tool off the strap, rear of tool first.

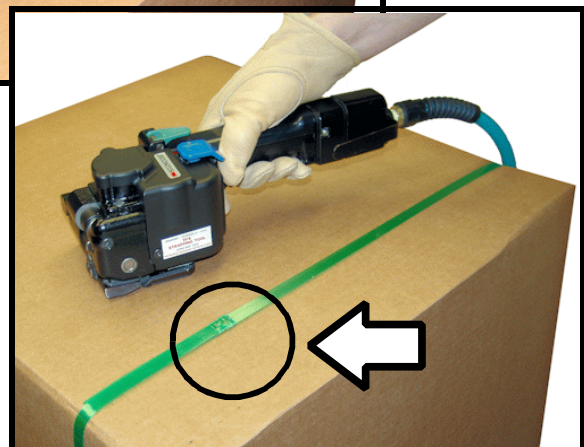
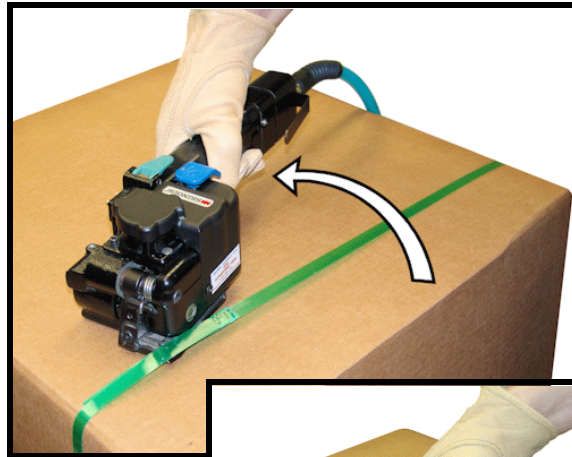

Inspect the joint to make sure the straps have been properly welded.

SEALING OPERATION

This tool is a Tension Weld® type sealer. A properly made joint will appear as shown in the illustration. If the joint does not appear as shown, then the operator must proceed as follows:

1. Insure that the tool operating instructions are being followed before applying another strap.
2. Cut the strap off and apply another.

A good weld will show some material displacement along the edges.



The welded area should extend the full length and width of the gripper impression.

If the joint still does not appear as shown, then inspect the tool for worn and/or damaged parts. Replace tool parts as needed. **NEVER HANDLE OR SHIP ANY LOAD WITH IMPROPERLY FORMED JOINTS.** Misformed joints may not secure the load and could cause serious injury.

TOOL ADJUSTMENT - WELD TIME

Weld time has been factory adjusted to provide acceptable weld strength when using High Strength Tenax (polyester) type strap.

Weld time may need to be adjusted due to air supply differences, tool wear, etc. Adjustments are made by turning the small slotted screw, located beneath the weld housing at the rear of the tool, using a small screwdriver. Turn the screw clockwise to increase weld time and counterclockwise to decrease weld time.

Establishing the correct weld time is a matter of trial and error and should be conducted as follows.

1. Adjust the screw in 1/16 to 1/8 turn increments only.
2. Apply a strap and make a weld.
3. Compare the weld made with the illustrations shown above. A good weld will displace some material along the outer edges of the joint.
4. If you are unable to produce an acceptable joint or if you have any questions as to whether your tool is producing good weld strength, contact -your Signode Sales Representative.

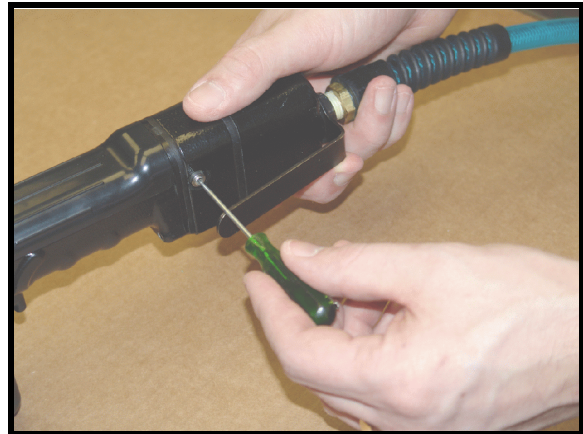

TOOL ADJUSTMENT - STRAP CUTTER

The VFX strap cutter has two serrated cutting edges. After the first edge has become dull or strap cut-off becomes difficult the blade can be remounted to use the second cutting edge. Once both edges have become worn the blade should be replaced. Use the instructions below to remount, install and adjust a new cutter blade.

NOTE: The small spring (Key 98) contained in the holder does not need to be removed to change the cutter blade.

1. Using a 3mm Allen wrench, remove the 3 screws (Key 61) which secure the outer cowling cover to the tool. Remove the cowling.
2. Remove the cutter cover (Key 120) by removing the two screws (Key 42) which secure cover.
3. Remove the two smaller screws (Key 39) which mount the cutter blade to the holder (Key 3).
4. Rotate the cutter blade to the new cutting edge and reinstall the mounting screws.

NOTE: If both cutting edges are worn replace the cutter blade at this point.

5. Once the cutter holder has been inspected and reinstalled, continue to reinstall the cover.
6. Run a few test cycles on the tool to confirm that the strap cut-off performs properly.

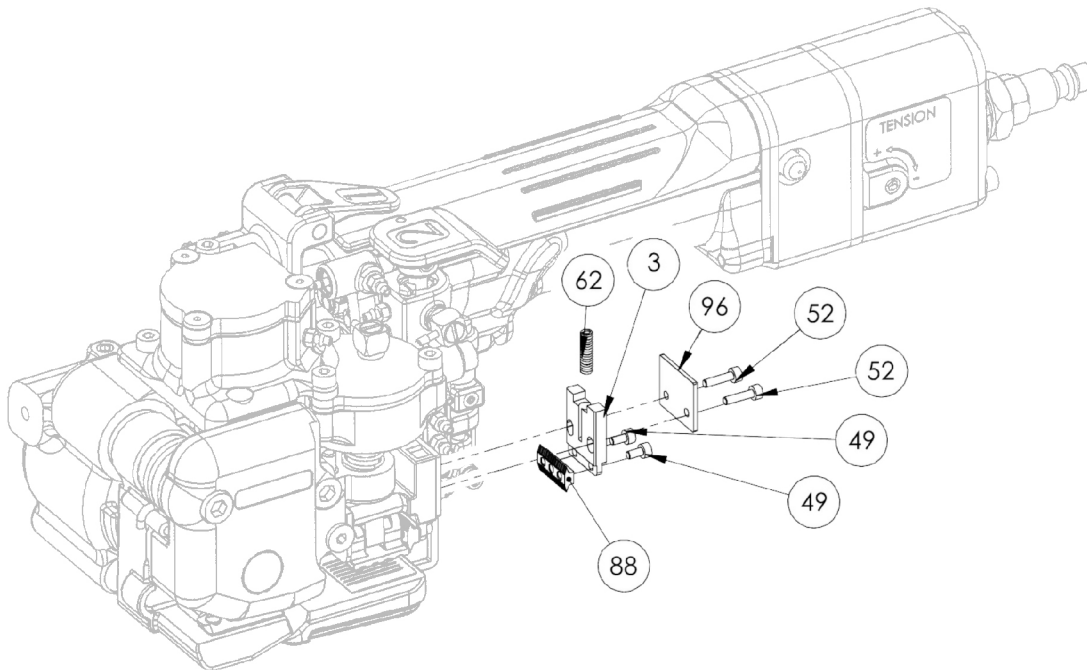

PARTS LIST - TOOL

<u>Key</u>	<u>Qty</u>	<u>Part No.</u>	<u>Description</u>
1	1	429538	Weld Plate Assembly
2	1	429479	Cylinder Housing
3	1	429469	Cutter Insert Holder
4	1	429429	Lower Weld Gripper
5	1	429280	Contact Plate
6	1	273842	Pin
7	1	425120	Slider Link
8	1	429540	Upper Gripper
9	1	427724	Pivot Pin
10	1	429507	Torrington HK-1010 Needle Bearing
11	1	429189	Cylinder Cap
12	2	427734	Pivot Bushing
13	1	428641	Pivot Pin
14	1	429571	Foot Lever
15	1	429460	Cylinder Gasket
16	1	428975	Spring Retainer
17	2	429414	Piston
18	1	429289	Motor Module Assembly
19	1	014518	Feedwheel
20	1	428043	Feedwheel Shaft
21	1	008734	Bearing B542
22	1	429449	Spiroid Gear 14.33:1
23	1	428588	Tensioner Foot Assembly
24	1	427897	Wear Ring
25	1	422809	Roller Bearing
26	1	008552	Oil Seal
27	1	428587	Foot Spring
28	2	428751	O-ring SAE# 110
29	2	428517	O-ring SAE# 214
30	1	023096	O-ring SAE# 131
31	2	023446	O-ring SAE# 12
32	1	023014	Spacer
33	2	023093	Key, Woodruff
34	1	427891	Bearing Cap
35	1	023097	Bearing, 9101k
36	1	434756	M6 X 10 SSS Cone
37	2	429462	M4 X 5 SSS Cone
38	1	429421	Torrington S7PP Ball Bearing
39	1	009175	35mm Int. Ret. Ring (TA# N5000-137)
40	2	429191	1/2" Int. Ret. Ring
41	1	429427	5/16" Int. Ret. Ring
42	2	426145	Torrington RC-061008 Roller Clutch
43	1	428093	Torrington HK-0509 Needle Bearing
44	1	428060	Brake Roller
45	1	428056	Brake Pin
46	1	428161	Brake Lever
47	1	428162	Pawl
48	1	429196	Hook Pin
49	2	262456	M3 X 6 SHSC
50	5	280851	M4 X 12 SHSC
51	1	010047	M6 X 60 SHSC
52	4	259935	M3 X 12 SHSC
53	1	280830	M6 X 16 SHSC
54	2	256747	M4 X 16 SHSC
55	3	170304	M5 X 16 SHSC
56	1	429430	M5 Spacer
57	1	428059	Brake Spring
58	1	428546	Mb0510 Garlock Bushing

<u>Key</u>	<u>Qty</u>	<u>Part No.</u>	<u>Description</u>
59	1	010036	M6 X 16 SFHCS
60	1	429107	Signode Sticker
61	1	429281	Lift Tab
62	1	429284	Spring Lc-032b-08-m
63	1	429287	Piston Rod
64	1	004238	#10 Lockwasher
65	1	429288	Spring LC-036g 03 M
66	1	429312	Cylinder Gasket
67	1	429313	Cylinder Cover
68	1	429315	Opening Lever (Casting)
69	10	428435	Barb Fitting
70	1	429325	Trigger
71	1	429326	Trigger Rod
72	1	429406	Valve Lifter
73	3	428530	Plug
74	1	429408	Weld Button
75	1	429409	Button Stop
76	1	429410	Air Fitting
77	2	428053	EA-LB20-slot
78	1	429192	Retaining Washer
79	1	429193	Pivot Pin
80	1	429412	MB0505DU Garlock Bushing
81	1	429413	MB0406DU Garlock Bushing
82	3	425171	3/8" Ext Ret Ring
83	2	429425	Delrin Washer
84	1	429431	Delrin Washer
85	1	429448	Spiroid Pinion 14.33:1
86	1	429453	Strap Spacer
87	2	429598	M4 X 6 SHCS
88	1	429457	Eccentric Shaft
89	1	428991	Cutter Insert
90	2	422572	Pin
91	1	429454	Brake Wheel Assembly
92	1	429463	M3 X 5 SSS Cone
93	4	429190	M4 X 10 SHCS X-low
94	1	429299	Pulley Assembly
95	2	429472	1.0 Wide X Ø5.0 I.d. Metric O-ring
96	1	429162	1.0 Wide X Ø6.0 I.d. Metric O-ring
97	1	429474	Cutter Cover Plate
98	1	274105	Strap Guide
99	1	429541	#10-32 X 1/4(low) SHCS
100	1	428746	M5 X 16 SHCS (extra Low)
101	1	015315	Torrington B-65 Needle Bearing
102	1	429545	Spacer
103	2	428196	Ø1.5 X 10 Roll Pin
104	1	429317	Valve Assembly
105	1	429556	Stop Pin
106	1	429561	Housing Assembly
107	1	423590	Rolled Pin
108	1	429562	Tension Valve
109	1	429506	Ms24585-103 Compression Spring
110	1	429504	5/16-18 X 5/32" SSS
111	1	429505	Detent
112	1	280824	M6 X 40 SHCS
113	1	429544	Drive Belt
114	1	429424	Weld Belt
115	1	426652	Ø5mm E-ring
116	1	429569	Piston Rod
117	1	428515	Extension Spring

<u>Key</u>	<u>Qty</u>	<u>Part No.</u>	<u>Description</u>
118	1	429591	Gear Housing Assembly
119	1	274104	Gripper Plug
120	1	429187	Side Plate
121	2	429590	Thrust Washer
122	1	429594	M3 X 10 SSS Cup
123	4	429411	ET-20 Air Fitting
124	1	429436	Signal Air Line (7.608) White
125	1	429497	Airline #1 (1.75") Black
126	2	429487	Airline #2 (.625") Dark Green
127	1	429446	Airline #3 (.75") Gray
128	1	429494	Airline #4 (1.25") Orange
129	1	429486	Airline #5 (1.1") Clear
130	1	429490	Airline #6 (1.5") Yellow
131	1	429489	Airline #7 (2.5") Brown
132	1	429496	Airline #8 (1.6") Purple
133	1	429492	Airline #9 (2.4") Pink
134	1	429495	Airline #10 (3.0") Light Green
135	1	429493	Airline #11 (7.5") Blue
136	1	429447	Airline #12 (7.25") Red
138	1	429596	Pigtail Assembly (optional)

- When ordering parts please indicate tool model, part number and description.
- Recommended spare parts are underlined and should be stocked.
- Common hardware parts can be obtained at any local hardware supply.



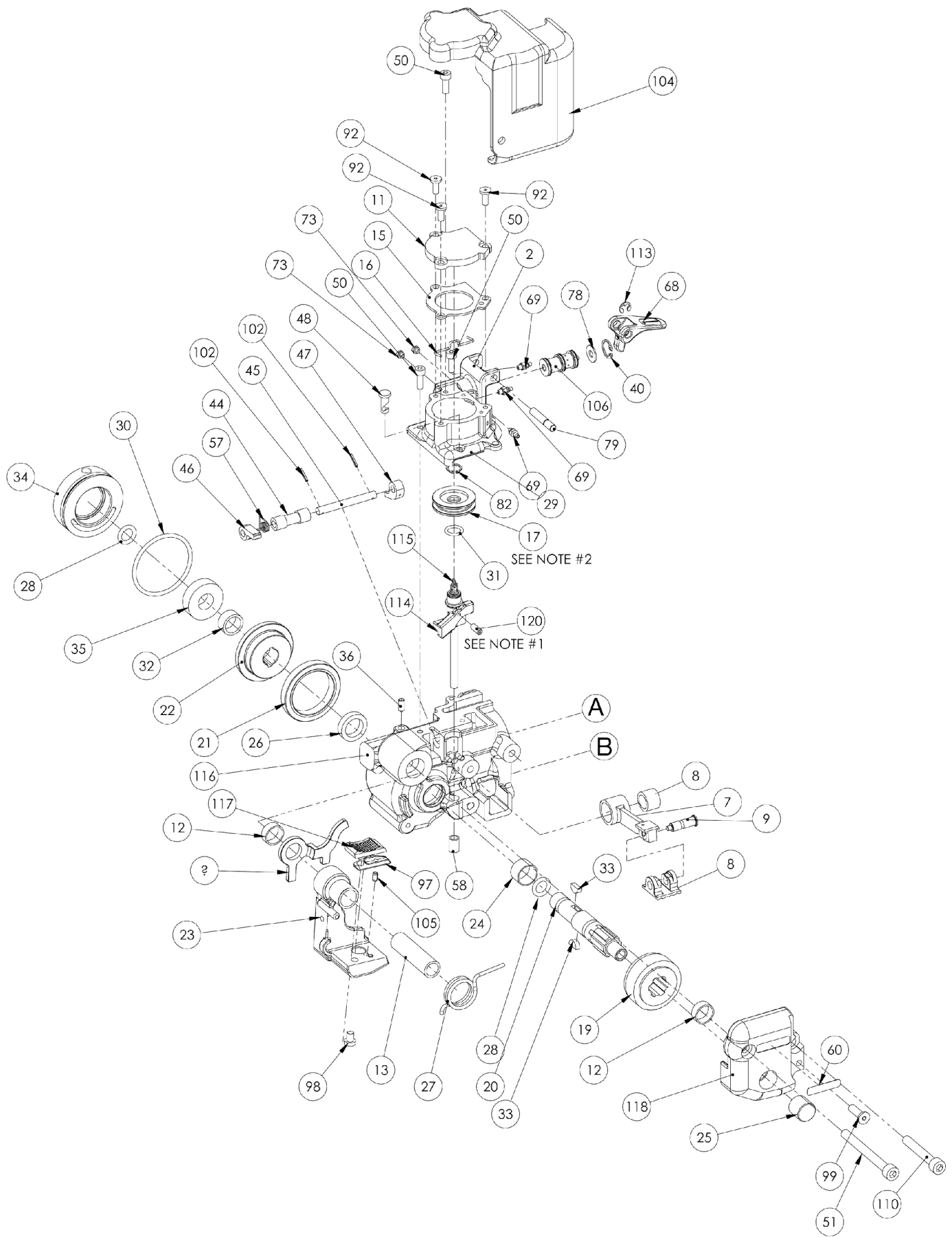

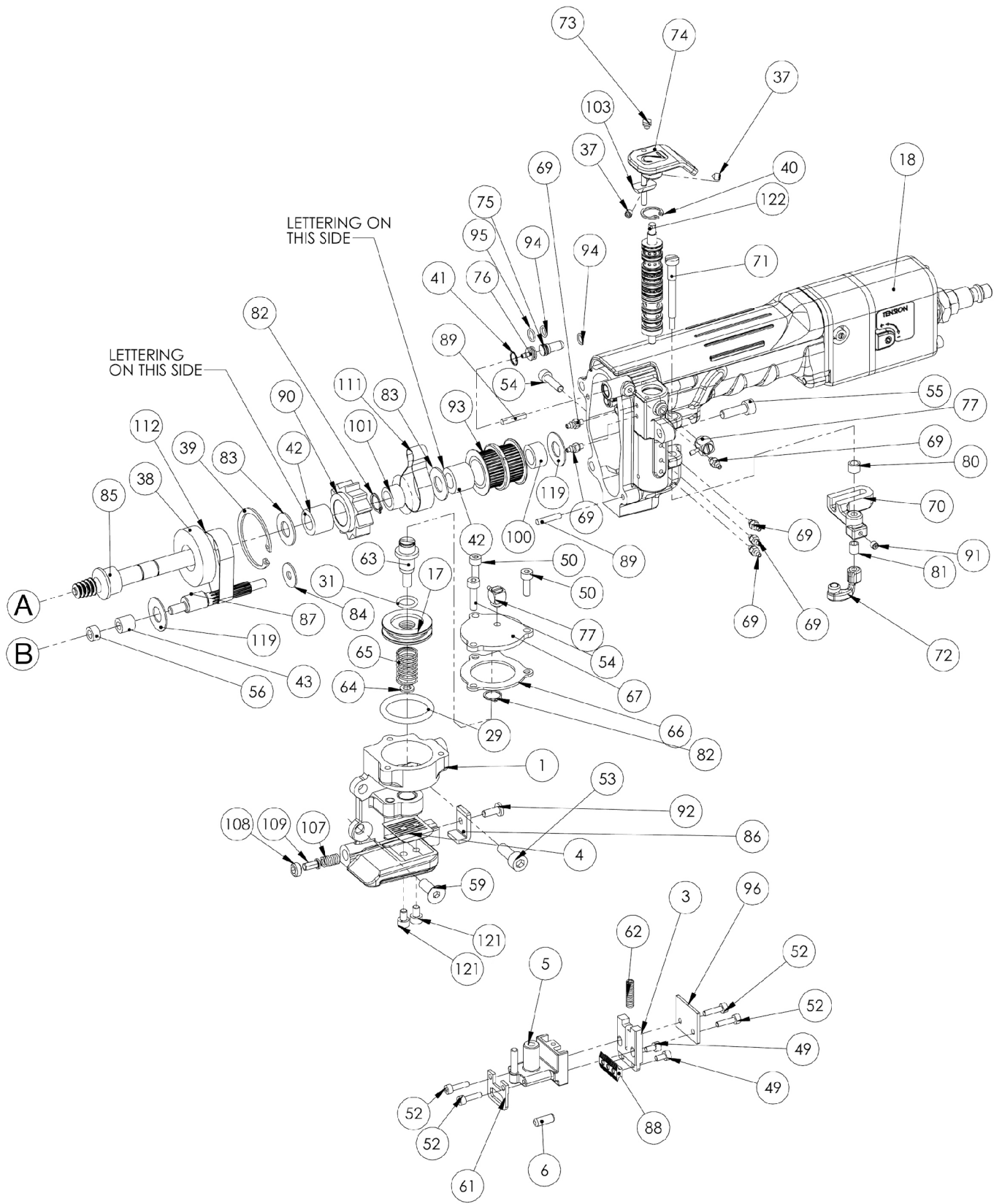

PARTS LIST - MOTOR

<u>Key</u>	<u>Qty</u>	<u>Part No.</u>	<u>Description</u>
1	3	428746	M5 X 16 SHCS (extra Low)
2	1	280851	M4 X 12 SHCS
3	2	429100	Ø1.5 X 12 Dowel Pin
4	1	429160	Timer Plate
5	1	424377	Check Valve
6	1	425310	Flow Control
7	1	428543	Valve Cap
8	1	428455	Timing Chamber
9	3	428435	Barb Fitting
10	1	428432	Seal Plate
11	1	428450	Timer Valve
12	1	024631	Filter Assembly
13	1	020704	Hansen Plug
14	1	428434	Valve Block
15	2	429105	Belleville Washer
16	1	429000	Lock Washer
17	1	429014	Washer
18	1	429013	Motor Ring
19	1	429166	Transition Plate
20	1	428977	Gasket
21	4	091624	O-ring SAE #10
22	2	022789	O-ring SAE #16
23	1	428976	Gasket
24	1	429094	Gasket
25	2	422572	Pin
26	1	429323	Motor Housing
27	1	429314	Cover
28	1	428093	Torrington HK-0509 Needle Bearing
29	1	015315	Torrington B-65 Needle Bearing
30	1	429296	Torrington HK-0808 Needle Bearing
31	1	429470	Locator Bushing
32	1	429294	Bearing Plate
33	4	429543	INA HK-0408 Needle Bearing
34	2	424392	Ø4mm E-ring
35	2	429542	Idler Pin
36	1	429572	Muffler
37	1	429249	Motor Assembly
38	2	429300	Ø1.5 X 10 Dowel Pin
39	1	429291	Motor Mount
40	1	429598	M5 X 16 SHCS (extra Low)
41	2	429573	Motor Valve
42	3	429595	M4 X 90 SHCS
43	1	424552	Cap
44	1	429599	M6 X 10 SSS Cone
45	1	429600	Info Sign, Tension
46	1	429627	O-Ring
50	1	428462	Belt hook (optional)

⚠ WARNING

Inspect all parts daily and replace them if they are worn or broken. Failure to do this can affect a product's operation and could result in serious personal injury.

- When ordering parts please indicate tool model, part number and description.
- Recommended spare parts are underlined and should be stocked.
- Common hardware parts can be obtained at any local hardware supply.

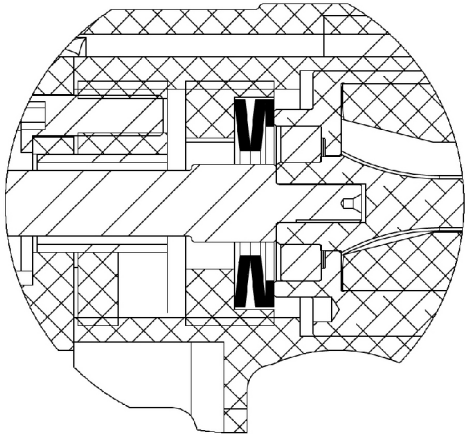

NOTE PROPER CONFIGURATION OF BELLEVILLE SPRINGS(429105) AND WASHER(429014)

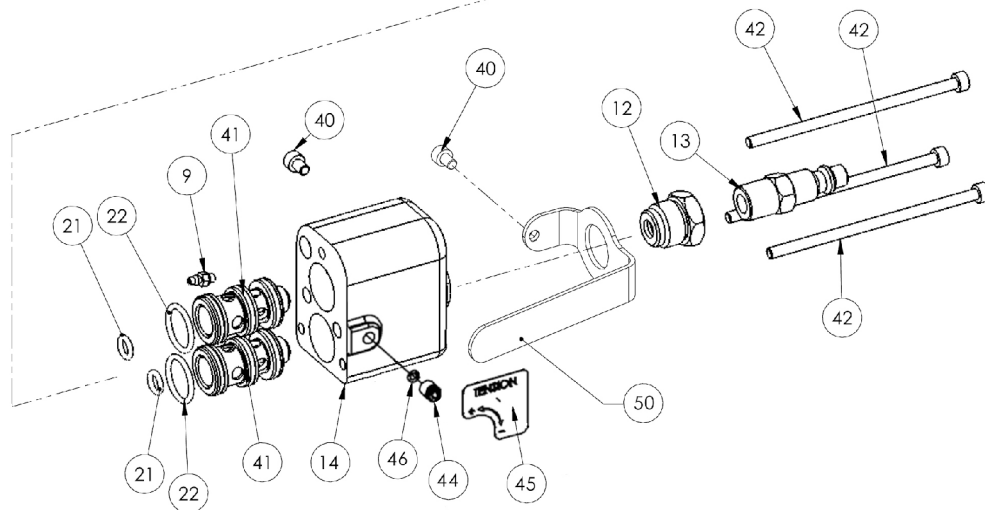
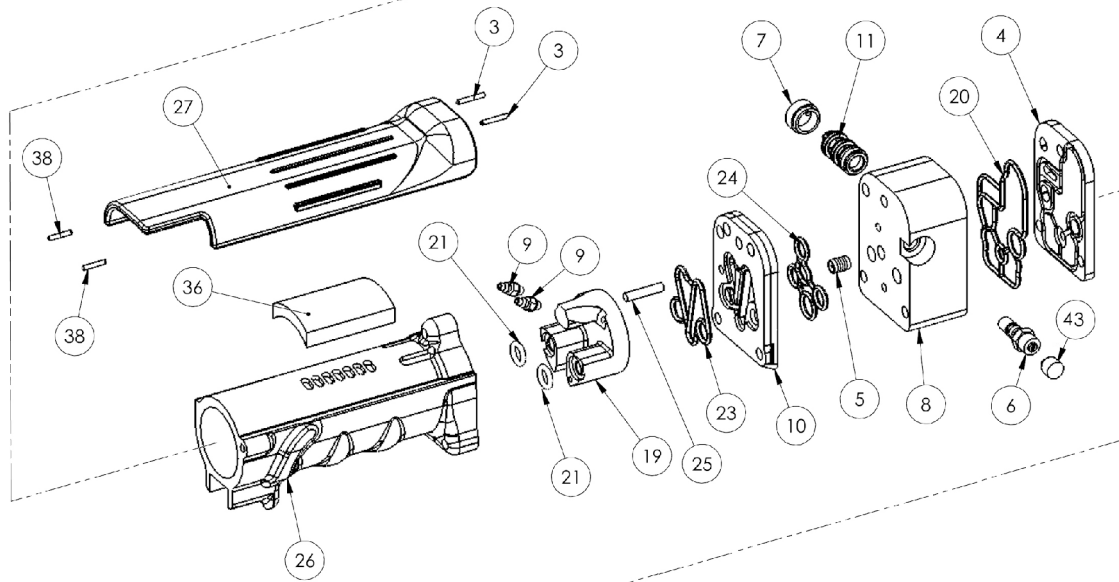
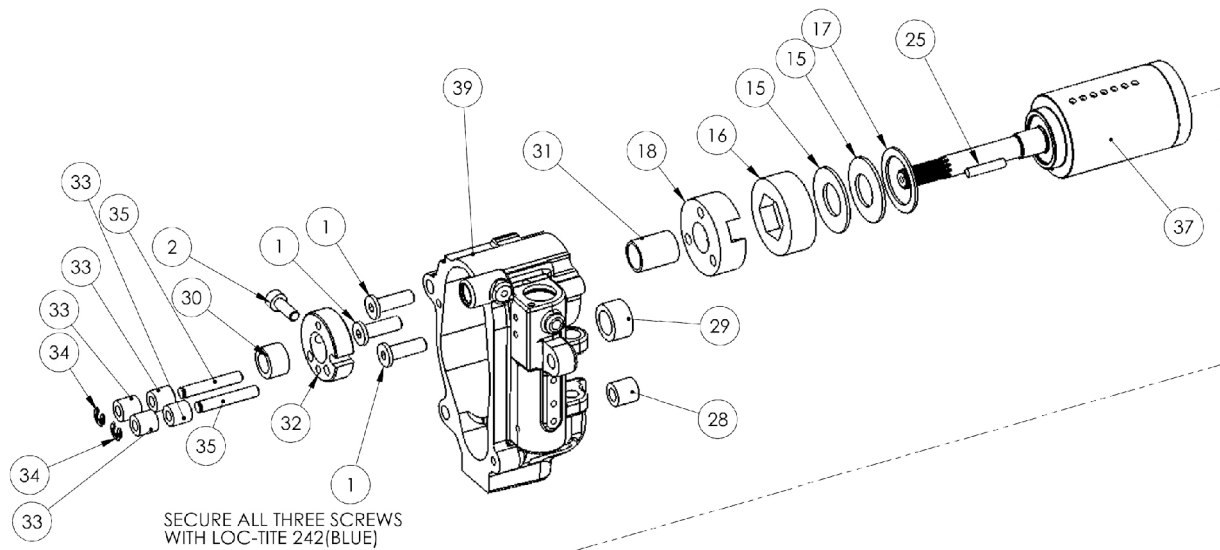

AIR LINE ROUTING

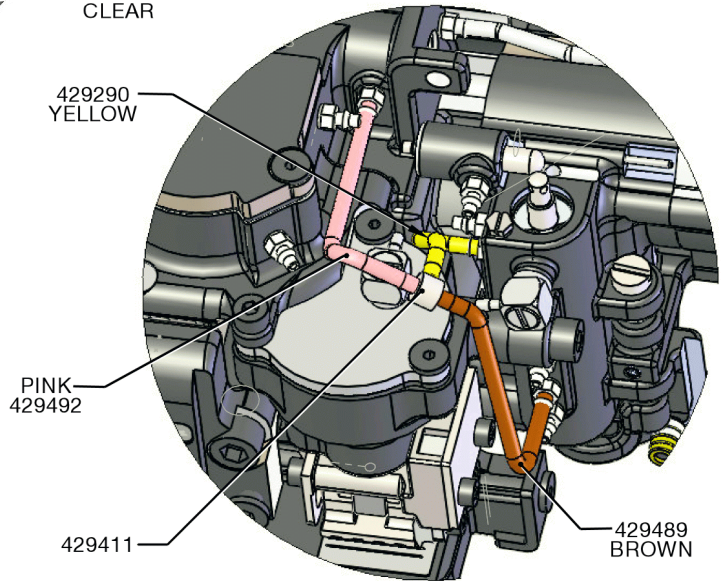
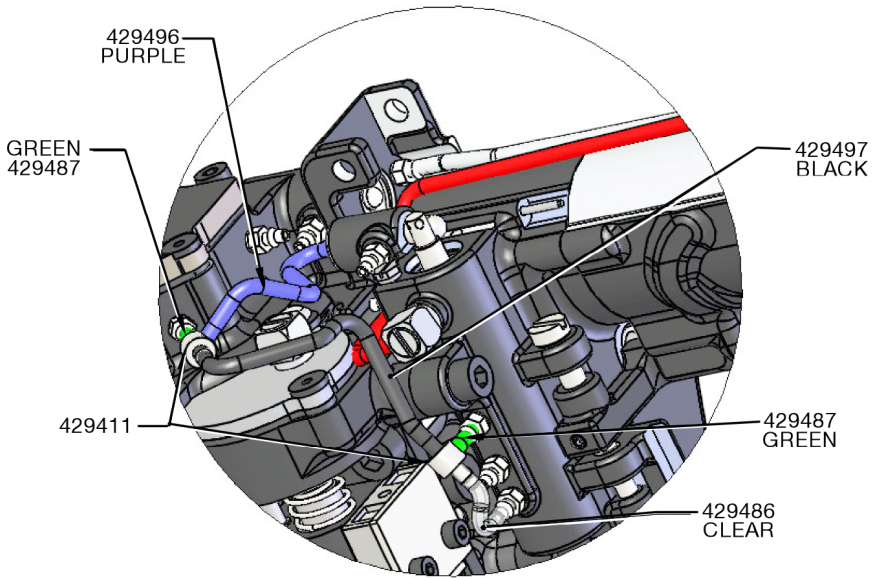
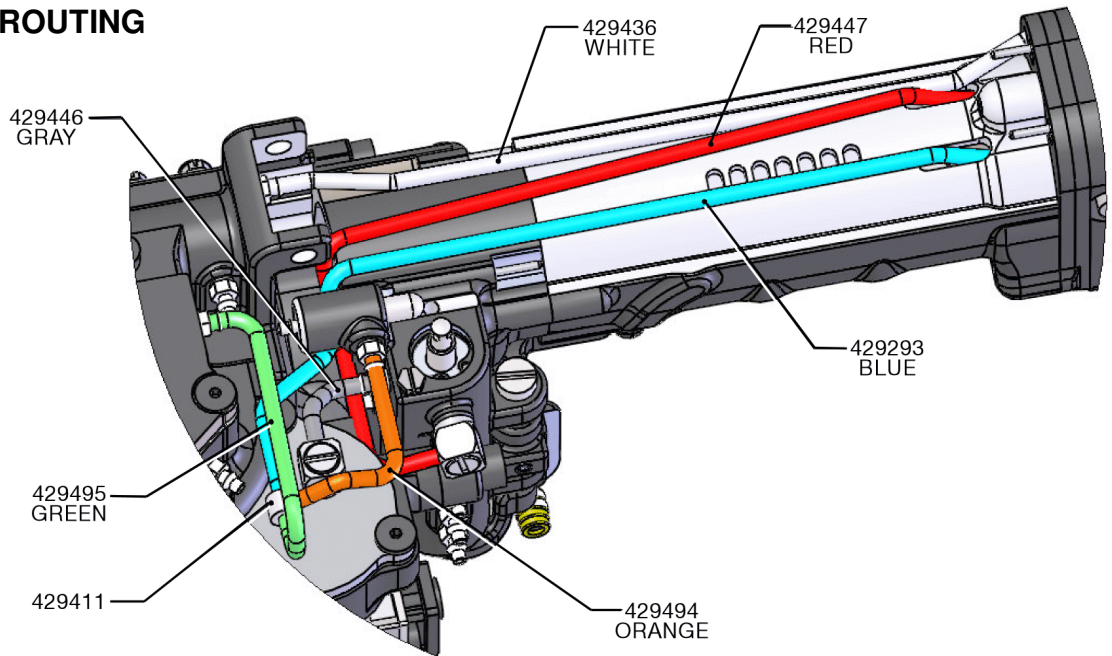

TROUBLESHOOTING

The following items are the most common types of tool malfunctions. For symptoms or remedies not shown, contact your Signode service representative for additional information and details. The following tool conditions are shown in this manual:

AIR SUPPLY

- #1 - The air motor is frozen.
- #2 - A leaking or sticking air valve.
- #3 - The tool runs sluggishly.

TENSIONING

- #4 - Feedwheel milling on strap and/or strap breaking.
- #5 - The top strap is being properly tensioned but the tool does not hold the bottom strap.
- #6 - The tool will not tension strap (air motor continues to run).

WELDING

- #7 - A poor weld identified by an incomplete area of weld.
- #8 - Incomplete or no weld.
- #9 - Strap is over welded.
- #10 - Motor shut-off is sluggish.
- #11 - Strap weld time is erratic.
- #12 - Weld time is too long.

CUT-OFF ACTION

- #13 - The cut-off has become difficult.
- #14 - Weld strap is misaligned.

MISCELLANEOUS

- #15 - Tool will not open.

#1 CONDITION: The air motor is frozen.	
CAUSE	REMEDY
The motor is dry, hindering it from providing maximum performance.	Add several drops of oil into the motor through the air inlet. Hook the tool up to air, depress and hold the operating lever while gently tapping the motor with a rubber mallet. Repeat this procedure several times if necessary.

#2 CONDITION: Air valve leaking or sticking.	
CAUSE	REMEDY
Worn, damaged or dirty O-ring on valve stem.	Clean and lubricate the valve stem assembly and the valve sleeve assembly. Replace the O-ring on the valve stem if necessary.

#3 CONDITION: The tool runs sluggishly.	
CAUSE	REMEDY
1. The air filter-regulator-lubricator is malfunctioning or is not properly maintained.	1A. Check the regulator to see that the correct air pressure is getting to the tool. 1B. Check to see the filter unit is clean and functioning properly. 1C. Examine the lubricator to see there is oil in the bowl and that oil is seen dripping from the sight dome as the tool operates. This assures the air motor is being properly lubricated.
2. The tool may run sluggishly due to a clogged or dirty motor filter screen due to a lack of properly filtered air supply.	2. Remove the Hansen plug at the inlet to the air motor and examine the filter screen in the filter assembly and clean it if necessary. See "Special Instructions", page 9, on removing Hansen plug.
3. The tool may run sluggishly due to an improper air motor adjustment or a clogged or dirty vibrator assembly.	3. Refer to Parts Removal and Replacement, Air Motor, for proper motor adjustment. For clogged or dirty weld assembly, see troubleshooting remedy under "Welding".
4. The end plates, pinion teeth on the rotor and the rotor blades are worn, dirty or rusted.	4. Carefully remove the air motor from the tool and disassemble it. If these parts are only dirty, clean, thoroughly oil and reassemble. If they are worn or rusted, replace them.

#4 CONDITION: Feedwheel milling on strap and/or strap breaking.	
CAUSE	REMEDY
1. Feedwheel is clogged with dirt or strap residue.	1. Clean teeth on feedwheel with the special brush provided.
2. Worn teeth on the feedwheel.	2. Replace the feedwheel.

#5 CONDITION: The top strap is being properly tensioned but the tool does not hold the bottom strap.	
CAUSE	REMEDY
1. The gripper plug may be packed with dirt or strap residue preventing the teeth from penetrating the strap.	1. Clean the gripper plug with the special non-metallic tool brush.
2. Worn teeth on the gripper plug.	2. Replace the worn plug. Since the feedwheel and gripper plug are prevented from contacting one another by an inside shoulder on each part, it is not often these parts have to be replaced.

TROUBLESHOOTING, Continued

#6 CONDITION: The tool will not tension strap (air motor continues to run).	
CAUSE	REMEDY
Worn tension drive belt.	Replace as required.

#7 CONDITION: A poor weld identified by an incomplete area of weld.	
CAUSE	REMEDY
The grippers have become clogged with strap residue or the bearings in the weld mechanism are extremely dry. Welding is achieved by a combination of vibration and downward pressure of the upper gripper. Either a restriction of motion or a reduction of downward pressure will cause a poor weld.	Dismantle and clean the weld mechanism by brushing away the strap residue or washing the entire unit in a solvent. When a solvent is used it is imperative the assembly be blown dry to remove all solvent. Check for dry or worn bearings in the slider link and gear housing. Replace or lubricate as required. If the tool has been used extensively, examine the teeth on the upper and lower grippers for wear. Replace if worn. Lubricate the weld mechanism with Mo-Lith #2 grease and reassemble.

#8 CONDITION: Incomplete or no weld.	
CAUSE	REMEDY
1. Improperly set weld time adjustment.	1. Adjust weld time as required per instruction in this manual.
2. Worn teeth on upper or lower gripper.	2. Replace as required.
3. Insufficient air supply pressure.	3. Remedy as required.
4. Worn drive belt.	4. Replace as required.
5. Worn slider link.	5. Replace as required.

#9 CONDITION: Strap is over welded.	
CAUSE	REMEDY
Improper weld timing adjustment.	Decrease weld timing as needed.

#10 CONDITION: Motor shutoff is sluggish.	
CAUSE	REMEDY
1. Dirty air filter in air logic circuit.	1. Replace as required.
2. Air leakage in the timing circuit.	2. Check air lines and fittings for leaks.

#11 CONDITION: Strap weld time is erratic.	
CAUSE	REMEDY
Dirty or very dry valve in air motor valve housing.	Add a several drops of airline oil into the air inlet of the tool and cycle several times to lubricate. If the problem persists, review the air motor valve housing maintenance instructions found in this manual.

#12 CONDITION: Weld time is too long.	
CAUSE	REMEDY
Too much oil in the air supply system of the tool.	Purge the tool of all excess oil. See instructions Excess Oil Removal found in this manual.

#13 CONDITION: The cut-off has become difficult.	
CAUSE	REMEDY
1. Strap residue jamming cutter mechanism.	1. Clean parts as required.
2. Adjust cutter as needed.	2. Adjust cutter per instructions in this manual as required.
3. Cutter blade worn or damaged beyond adjustability.	3. Follow cutter blade replacement procedures.
4. Broken or damaged cutter spring.	4. Replace as required.

#14 CONDITION: Welded strap is misaligned.	
CAUSE	REMEDY
The tool is not being operated properly.	Review "Tool Operation" on pages 10 & 11 of this manual for proper operation of tool.

#15 CONDITION: Tool will not open.	
CAUSE	REMEDY
Air motor vanes too dry.	Squirt 8 to 10 drops of air-line oil into tool inlet to lubricate air motor.

MAINTENANCE

TOOL

1. Always be sure the tensioner foot is free and periodically lubricate the support pin.
2. Clean the teeth on the feedwheel and the gripper plug with the special brush provided, (Part No. 023963).
3. Periodically clean the tool with an air hose.
4. Disassemble, clean and lubricate the welding mechanism.

GEAR HOUSING

Periodically check the gear housing portion of the tool:

1. Remove the end cap from the front of the gear housing by removing the set screw and pulling the end cap off.
2. Check for adequate lubrication and wear of the Spiroid worm and gear.
3. This portion of the tool should be from 20% to 50% full of Non-Fluid Oil K-55.
4. Reinstall the end cap.

TOOL OPTIONS

BELT HOOK - Part No. 428462

PIGTAIL ASSEMBLY - Part No. 429596

STRAP GUIDE - Part No. 014565

SUSPENSION BRACKET - Part No. 429610

STANDARD EQUIPMENT KIT - Part No. 429607



EU Declaration of Conformity
The Supply of Machinery (safety) Regulations
1992 (S.I. 1992/3073)

It is hereby declared that the undermentioned machinery has been designed and constructed to comply with the health and safety requirements defined in EC Directive 89/392/EEC

Machine Supplier: Signode, Division of ITW Ltd.
Queensway, Fforestfach
Swansea SA5 4ED

Machine Description: VFX Series

Machine Type: Pneumatic Combination Hand Strapping tool.

Provisions with which machine complies:

89/392/EEC, 91/368/EEC

Harmonized EuroNorms with which machine complies:

EN 292:1, EN 292:2, EN 294, EN 349

Technical Standards with which machine complies:

NA

Signature:

Date:

SIGNODE NEW TOOL WARRANTY

Signode Engineered Products Warrants that a new Signode strapping tool will operate per functional specifications for a period of sixty (60) days after the date of shipment to the owner's place of business. Normal wearing parts, as outlined in the Operation, Parts & Safety manual, are covered by a thirty (30) day warranty unless, in Signode's judgement, these parts have been subjected to abnormal or extreme usage. Signode's sole liability hereunder will be to repair or replace, without charge, F.O.B. Signode's Glenview, Illinois plant, any tool which proves to not operate per functional specifications within the stated period. Signode reserves the right to replace any tool which proves not to operate per functional specifications with a new or like-new tool of the same model if in Signode's judgement such replacement is appropriate. Any new replacement tool provided to an owner will carry a full sixty (60) day warranty. Any warranty repaired tool or like-new replacement tool will carry a warranty for the balance of the time remaining on the initial sixty (60) day warranty. This warranty will be extended to compensate for the time the tool is in Signode's possession for warranty repairs.

This warranty is void as to any tool which has been: (I) subjected to mis-use, misapplication, accident, damage, or repaired with other than genuine Signode replacement parts, (II) improperly maintained, or adjusted, or damaged in transit or handling; (III) used with improperly filtered, unlubricated air or improper strapping material, (IV) in Signode's opinion, altered or repaired in a way that affects or detracts from the performance of the tool.

SIGNODE MAKES NO WARRANTY, EXPRESSED OR IMPLIED, RELATING TO MERCHANTABILITY, FITNESS OR OTHERWISE EXCEPT AS STATED ABOVE AND SIGNODE'S LIABILITY AS ASSUMED ABOVE IS IN LIEU OF ALL OTHERS ARISING OUT OF OR IN CONNECTION WITH THE USE AND PERFORMANCE OF THE TOOL. IT IS EXPRESSLY UNDERSTOOD THAT SIGNODE SHALL IN NO EVENT BE LIABLE FOR ANY INDIRECT OR CONSEQUENTIAL DAMAGES INCLUDING, BUT NOT LIMITED TO, DAMAGES WHICH MAY ARISE FROM LOSS OF ANTICIPATED PROFITS OR PRODUCTION, SPOILAGE OF MATERIALS, INCREASED COSTS OF OPERATION OR OTHERWISE.

Considerable effort has been made to ensure that this product conforms to our high quality standards. However, should you experience any difficulties, please contact your Sales Representative providing samples and the manufacturing code specified on the tool.

Thank you for your help.

SIGNODE ENGINEERED PRODUCTS
Hand Tool Division
3620 W. Lake Avenue, Glenview, Illinois 60025

PART #	DESCRIPTION	AREA OF USE
LUBRICANTS		
177029	BROWN K-55 GREASE	CLUTCH DRIVES, INTERNAL GEARS, GEAR SETS
422792	WHITE LUBRIPLATE GR-132 GREASE	PNEUMATIC PARTS, AIR CYLINDERS, AIR VALVES, O-RINGS
422793	BLACK LUBRIPLATE 3000W GREASE	MOVING INTERNAL PARTS, JAWS, LINKS
432322	EP ACCROLUBE GREASE	HIGH FRICTION CONTACT PARTS
008556	LS-1236 AIR LINE OIL	AIR MOTORS, AIR VALVES
ADHESIVES		
422794	LOCTITE #222, PURPLE	LOW STRENGTH, SCREWS 1/4" (6MM) OR SMALLER SIZES
422795	LOCTITE #242, BLUE	MEDIUM STRENGTH, SCREWS 5/16" (8MM) OR LARGER SIZES
422796	LOCTITE #271, RED	HIGH STRENGTH, SEMI-PERMANENT SCREW APPLICATION
422797	LOCTITE #609, GREEN	PERMANENT, CURVED SURFACE PART CONTACT
274111	LOCTITE #380, BLACK MAX	PERMANENT, FLAT SURFACE PART CONTACT
CLEANING BRUSHES		
023963	SMALL BRUSH	FEEDWHEEL & GRIPPER TEETH
269589	LARGE BRUSH	FEEDWHEEL & GRIPPER TEETH