

OPERATION, PARTS AND SAFETY MANUAL



SIGNODE®

PHT-16/19

PNEUMATIC COMBINATION STRAPPING TOOL

**IMPORTANT!
DO NOT DESTROY**

**It is the customer's responsibility to
have all operators and servicemen
read and understand this manual.**

Contact your local Signode representative
for additional copies of this manual.

READ ALL INSTRUCTIONS BEFORE OPERATING THIS SIGNODE PRODUCT

SIGNODE • 3620 WEST LAKE AVENUE • GLENVIEW, ILLINOIS 60025 U.S.A.

⚠ WARNING

READ THESE INSTRUCTIONS CAREFULLY.

FAILURE TO FOLLOW THESE INSTRUCTIONS CAN RESULT IN SEVERE PERSONAL INJURY.

GENERAL SAFETY CONSIDERATIONS

1. STRAP BREAKAGE HAZARD.

Improper operation of the tool or sharp corners on the load can result in strap breakage during tensioning, which could result in the following:

- ! A sudden loss of balance causing you to fall.
- ! Both tool and strap flying violently towards your face.

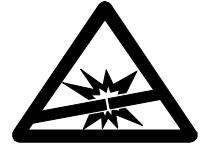

Failure to place the strap properly around the load or an unstable or shifted load could result in a sudden loss of strap tension during tensioning. This could result in a sudden loss of balance causing you to fall.

Read the tool's operating instructions. If the load corners are sharp use edge protectors. Place the strap correctly around a properly positioned load.

! Positioning yourself in-line with the strap, during tensioning and sealing, can result in severe personal injury from flying strap or tool. When tensioning or sealing, position yourself to one side of the strap and keep all bystanders away.

2. TRAINING.

This tool must not be used by persons not properly trained in its use. Be certain that you receive proper training from your employer. If you have any questions contact your Signode Representative.

3. EYE INJURY HAZARD.

Failure to wear safety glasses with side shields can result in severe eye injury or blindness. Always wear safety glasses with side shields which conform to ANSI Standard Z87.1 or EN 166.



4. FALL HAZARD.

Maintaining improper footing and/or balance when operating the tool can cause you to fall. Do not use the tool when you are in an awkward position.

5. CUT HAZARD.

Handling strap or sharp parts could result in cut hands or fingers. Wear protective gloves.



6. TOOL CARE, MAINTENANCE & PARTS REPLACEMENT.

! Take good care of the tool. Inspect and clean it daily, lubricate it weekly and adjust when necessary. Replace any worn or broken parts.

! ALWAYS disconnect the pneumatic connection to the tool when performing part removal and replacement procedures. NEVER connect a pneumatic source to a disassembled tool unless otherwise specified.

7. WORK AREA.

Keep work areas uncluttered and well lighted.

8. OPERATING SEQUENCE.

Use the correct Signode products for your application. If you need help contact your Signode Representative. Before using this sealless tool, read the Operation and Safety Instructions contained in this manual.

Signode tools and machines are designed and warranted to work together with Signode strapping and seals. Use of non-Signode strap, seals and/or manufactured or specified replacement parts may result in strap breakage or joint separation while applying strapping to a load or during normal shipping and handling. This could result in severe personal injury.

9. Before using this tool, read its Operation and Safety instructions.

- ! Do not exceed the operating air pressures stated elsewhere in the manual.
- ! Use Signode's approved filter-regulator-lubricator unit (P-008559).
- ! Never operate a pneumatic tool with a bottled air or gas source.
- ! For tension adjustments, follow instructions in this manual. For all other adjustments, repairs or cleaning of the tool, disconnect air supply.
- ! This tool is a Tension Weld® type sealer. A properly made joint will appear as shown in the illustration. If the joint does not appear as shown, then the operator must proceed as follows:



- A. Insure that the tools operating instructions are being followed before applying another strap.
- B. Cut the strap off and apply another.

If the joint still does not appear as shown, then inspect the tool for worn and/or damaged parts. Replace tool parts as needed. **NEVER HANDLE OR SHIP ANY LOAD WITH IMPROPERLY FORMED JOINTS.** Misformed joints may not secure the load and could cause serious injury.

10. CUTTING TENSIONED STRAP

Using claw hammers, crowbars, chisels, axes or similar tools can cause tensioned strap to fly apart with hazardous force. Use only cutters designed for cutting strap. Read the instructions in the cutter's manual for proper procedure in cutting strap. Before using any Signode product read its Operation and Safety Manual.

TABLE OF CONTENTS	Page
General Safety Instructions	2
Introduction	4
Specifications	5
Major Components	5
Pneumatic Information	6
Operating Instructions	10
Strap Joint Formation & Appearance	11
Part Replacement & Adjustments	12
Parts List	14
Troubleshooting	32
Maintenance	34
Changing Strap Size	35
Tool Options	36

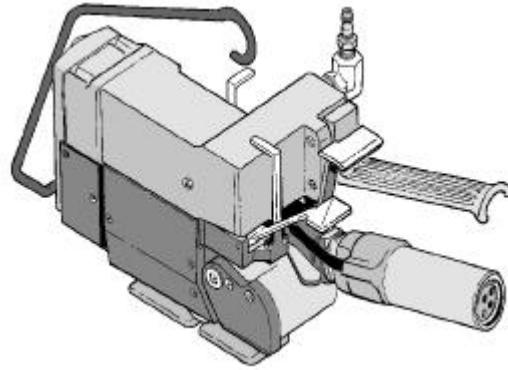

PHT-16, Part No. 423274
PHT-19, Part No. 424000

INTRODUCTION

The PHT is a pneumatically operated hand tool intended for use only with Signode strapping. The tool is easy to load, tension and seal.

Once the strap has been placed around the package, the operator puts both layers of strap into the tool, lowers the feed wheel, removes any strap slack and tensions the strap. The keyed tension-weld joint is then created and the strap is cut free of the supply.

This manual provides the information necessary for the operation of the PHT hand tool and lists all of the parts in the event maintenance is needed. Therefore, it is valuable and should be saved.

Fasteners are metric. Pneumatic components are English.

 WARNING

This tool was designed and tested using Signode strap. Using non-Signode strap may adversely affect the tool's tensioning capability and the strength of the joint

SPECIFICATIONS

Operating air pressure: 70-90 PSI (4.8-6.2 BARS)

Physical Dimensions (w/o hanger): H 140mm X W 110mm X L 260mm

Weight: 19 Lbs

MODEL	STRAP			STRAP TENSION @ 90 PSI
	TYPE	WIDTH	THICKNESS	
PHT-16	Tenax	16mm	1.0mm	400 Lbs
PHT-19		19mm	1.3mm	800 Lbs

MAJOR COMPONENTS

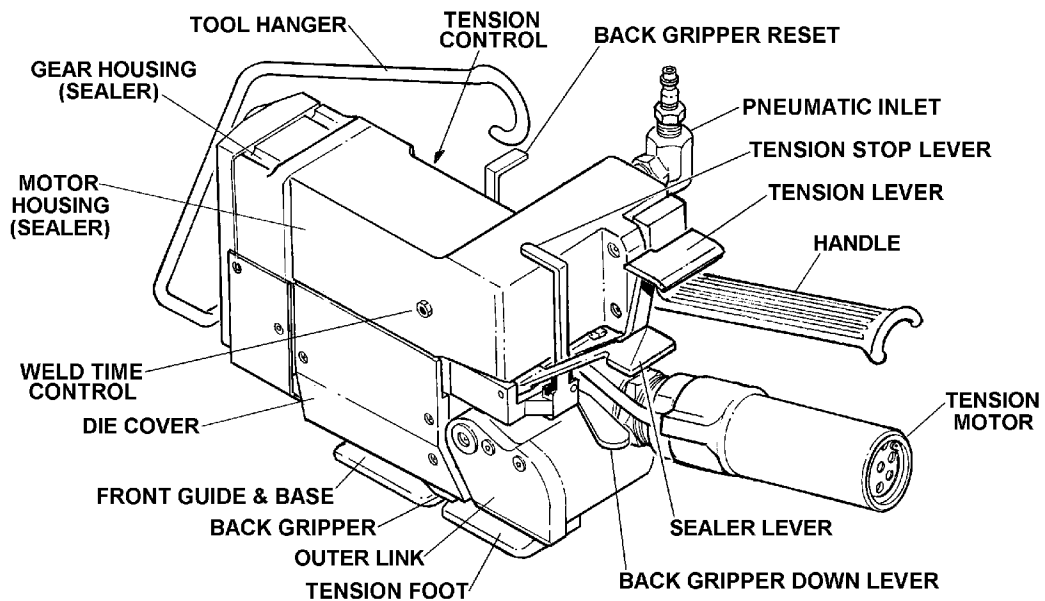

PNEUMATIC INFORMATION

AIR SUPPLY INSTALLATION

If compressor has a good dryer unit, use black pickled pipe. When a dryer unit is not installed, use galvanized or copper pipe.

To perform reliably, a pneumatic tool requires a continuous source of clean, water-free air at adequate pressure.

⚠ WARNING

Never operate this tool using a bottled air or gas source.
Bottled air/gas sources do not provide consistent operating pressure.

A filter-regulator-lubricator unit (P/N 173111) must be installed as close to the air tool as possible, preferably within 10 feet (3M). It should be placed in a convenient location where it can easily be drained, adjusted, and filled with oil. The air hose (P/N 008558) must have at least a 3/8" (9.5mm) I.D. A quick-connect press-on socket (P/N 008569) is installed on the stress spring end of the hose for convenient hookup to the air tool.

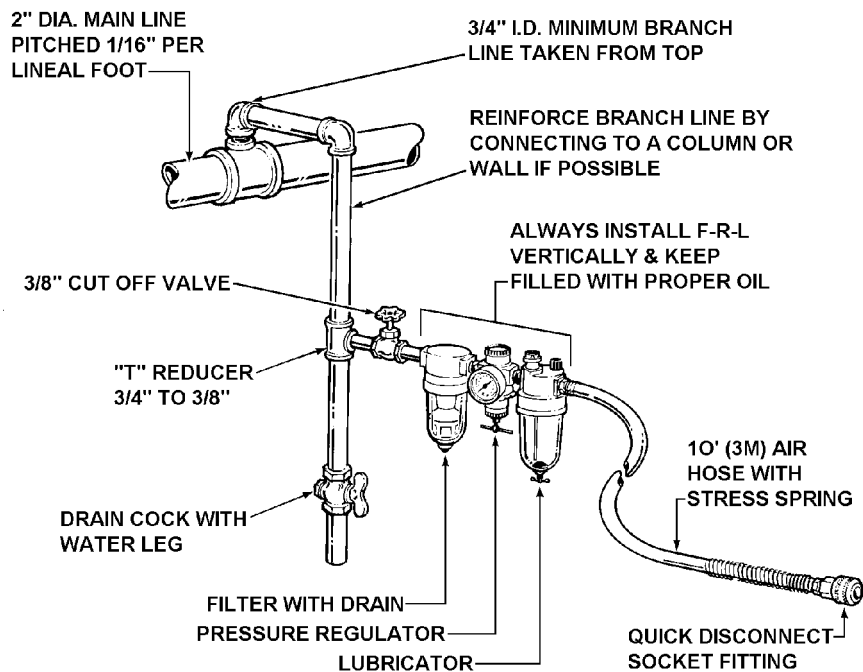

Filter and lubricator bowls are made of polycarbonate material. Do not install where bowls may be exposed to materials incompatible with polycarbonate. Certain oils, solvents, and chemicals or their fumes can weaken these bowls and possibly cause them to burst. Clean only with warm water. A cut-off valve placed ahead of the filter will be useful when cleaning the filter or replenishing the lubricator.

MOISTURE

Moisture is always present in air lines due to condensation within the lines as the air cools. Steps must be taken to remove this moisture and to keep it from the air tool. This is because water tends to wash away lubricants and cause corrosion, sticking and failure of internal parts.

The main line should be pitched so the far end terminates in a water leg. Branch lines are taken from the top of the main, never off the bottom. Every branch should have a water leg at its lowest point, with a drain cock which is drained daily.

If these precautions are taken and water is still present, an after cooler and a moisture separator are required between the compressor and the air receiver tank. A large air line separator can be installed in the air tool line, but precautions must be taken to insure that it will be drained daily, before the air tool is operated.

Water in air lines is a constant threat to the proper operation of air tools. Even near freezing operating conditions, a good refrigerant type dryer is essential. A good dryer will remove 95% or more of water right at the compressor. The remaining moisture is removed at the water leg in the piping system or in the filter, Signode Part No. 173111. Additional information is available in the Signode publication, "Air Supply Manual" Signode Part No. 186038. If you have any questions, contact your local Signode Representative.

LUBRICATION

The air motor must be properly lubricated. This is achieved by keeping the air line lubricator filled with oil and correctly adjusted. Without proper lubrication, the motor will become sticky and the tool will give low and erratic tension and be difficult to release from the strap.

Install the lubricator as close to the air tool as possible. The arrow on the lubricator's top surface must point in the direction of air flow.

For proper operation, oil must drop through the lubricator sight glass at a rate of 4 to 10 drops per minute. This rate is to be checked while the air tool is running free. Only 20% of this oil is actually delivered to the tool. The remaining oil drops back into the oil reservoir. The unit is factory set and should require no adjustment. If an adjustment is required, the adjusting screw on top of the lubricator may be turned as marked to reduce or increase the flow of oil.

The correct grade of oil must be used in the lubricator; too heavy an oil will not provide sufficient lubrication and will cause sticking and sluggish operation of the air tool.

Recommended oils are any good grade of rust and oxidation inhibiting oil with a viscosity of 80-120 S.U.S. at 100 degrees Fahrenheit. (0.15 to 0.25 cm² /sec. at 38 degrees Celsius), such as:

Non Fluid Oil Co., grade #LS-1236
Signode oil - Part No. 008556

If necessary, use SAE #5 or SAE #10, non-detergent, cut 1:1 with kerosene. Some oils contain anti-wear additives which may disable the air motor. Be certain to use recommended oil.

Several drops of lubricator oil added to the inlet of the air motor or into the air line each day will help insure good operation. A noticeable reduction of air motor performance can usually be corrected by squirting a few drops of oil into the air line.

PNEUMATIC INFORMATION, Continued

COLD WEATHER OPERATION

If a tool does not operate satisfactorily in freezing temperatures, certain steps can correct the problem. The following steps can be taken to improve cold weather operation of the tool:

- a. An air line dryer adjacent to the compressor.
- b. Use lubricant recommended by Signode. Signode has tested the use of anti-freezes, none work well in air tools; the tool will gum up when anti-freezes are introduced and will not function properly. The best lubricant for freezing weather is the 1 to 1 oil and kerosene combination.
- c. If possible, run the air supply line to a indoor located Filter-Regulator-Lubricator or relocate the F-L-R to a warmer operating area.

AIR CONSUMPTION

Air consumption in cubic feet per minute (cfm) for the PHT can be calculated as follows:

$$\text{cfm} = (a) \times (b) \times (0.60)$$

a = Number of straps applied per minute.

b = Number of seconds air motor is on per strap during tensioning, from start to finish sealing.

0.60 = PHT efficiency ratio.

Example calculation:

$$(a) \times (b) \times (0.60) = 4 \times 5 \times 0.60 = 12.0 \text{ cubic ft/min.}$$

Peak strapping load is 4 straps/minute, so a=4.

Air motor is on 5 seconds/strap, so b=5.

PHT efficiency ratio is 0.60.

Air pressure is assumed to be 90 psig with the recommended size and length of air hose. Volume of air at room temperature and sea level pressure, or so-called 'free air' conditions. For more detailed information about air supply systems, refer to Signode manual Part No. 186038.

AIR LINE PRECAUTIONS

Too much air pressure can cause internal tool damage. The maximum operating air pressure for this tool is 90 psig.

WARNING

Strap breakage hazard. Strap breakage can result in severe personal injury.
Strap can break during tensioning if inlet air pressure to tool exceeds 90 psig.
Maximum operating air pressure is 90 psig.

AIR PRESSURE DROP

Confirm air pressure calibration by comparing it to a master gauge placed in-line where the quick disconnect fitting attaches to the tool.

Air pressure at the tool can then be monitored as the tool cycles. Use the following information shown on the chart below for comparing the various minimum air pressures while the PHT tool cycles.

If pressure readings fall below the minimums, inspect your air supply system as well as the tool for worn and/or broken parts. Contact your Signode representative if you have any questions.

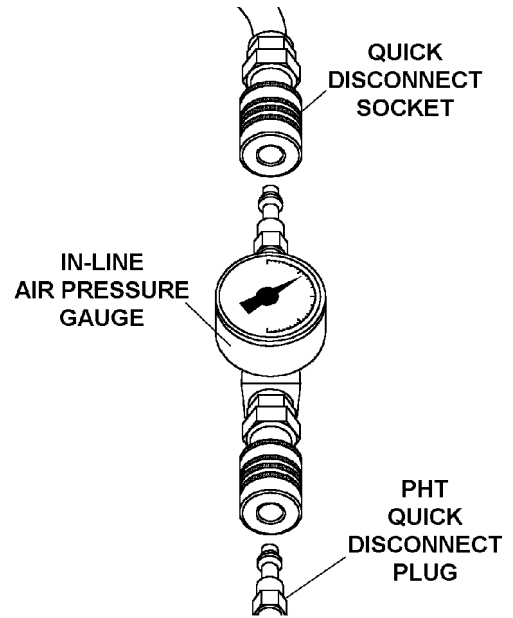

AIR LINE PRESSURE MINIMUMS FOR CYCLING TOOL

IN-LINE GAUGE READING PSI (BAR)			
SUPPLY/STATIC	TAKE-UP	STALL	WELDING
90 (6.2)	61 (4.1)	80 (5.4)	63 (4.2)

OPERATING INSTRUCTIONS

WARNING

Wear safety glasses and gloves.
Always position yourself to one side of the strap.
Make sure all bystanders are clear before proceeding.

1. STRAP LOADING

Make sure the strap being used is the proper size for the tool model being used. Refer to the Specifications section on page 5 of this manual.

Pass the strap over the top of the package then bring the lead end around and up. This will result in creating a **TOP STRAP** and a **BOTTOM STRAP**. They will be referred to later in these instructions.

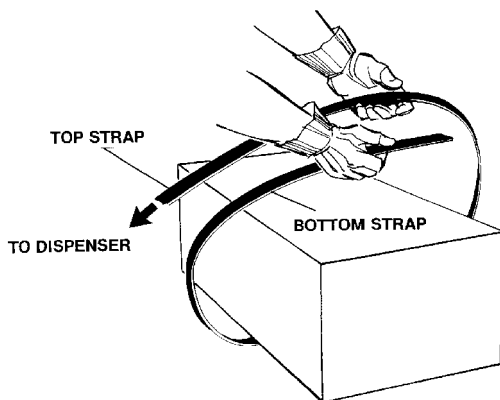

2. Insert the bottom strap through the front gripper, under the back gripper and under the tension foot.

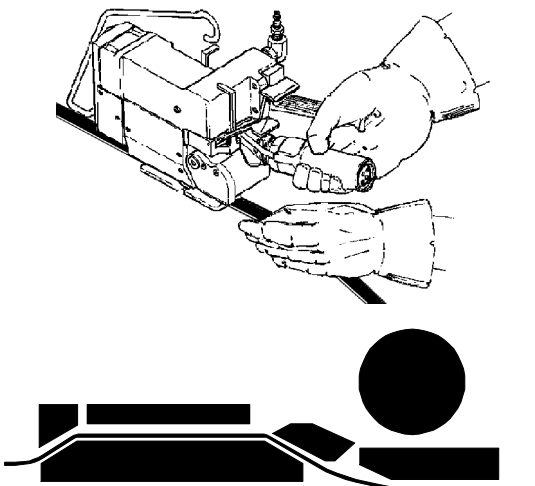

3. Lower the back gripper down onto the strap by pressing the gripper down lever (Black).

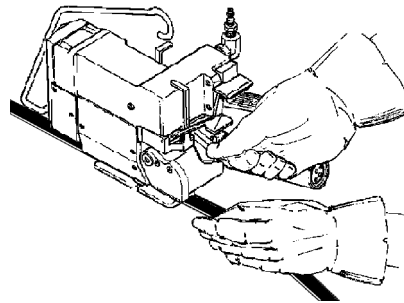

4. Insert the top strap into the tool, over the bottom strap and under the feedwheel.

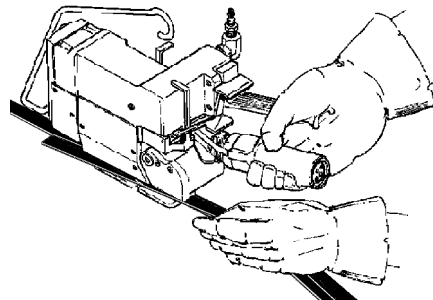

5. Push the tension lever (Green) down to tension the strap.



6. Push the sealer lever (Blue) to weld the straps together. Pull back the cut off strap from the rear of the tool.

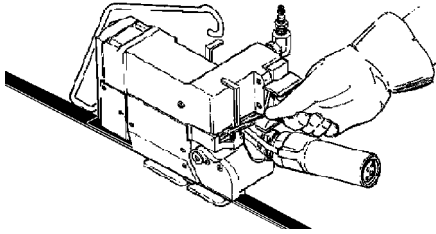

7. Remove the tool from the package by swinging the back of the tool to the right.

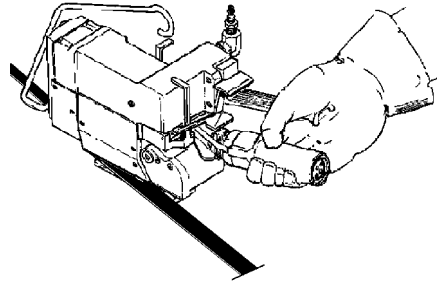

STRAP JOINT APPEARANCE & FORMATION

- ! Do not exceed the operating air pressures stated elsewhere in the manual.
- ! Use Signode's approved filter-regulator-lubricator unit (P-008559).
- ! Never operate a pneumatic tool with a bottled air or gas source.
- ! For tension adjustments, follow instructions in this manual. For all other adjustments, repairs or cleaning of the tool, disconnect air supply.
- ! This tool is a Tension Weld® type sealer. A properly made joint will appear as shown in the illustration. If the joint does not appear as shown, then the operator must proceed as follows:



- A. Insure that the tools operating instructions are being followed before applying another strap.
- B. Cut the strap off and apply another.

If the joint still does not appear as shown, then inspect the tool for worn and/or damaged parts. Replace tool parts as needed. **NEVER HANDLE OR SHIP ANY LOAD WITH IMPROPERLY FORMED JOINTS.** Misformed joints may not secure the load and could cause serious injury.

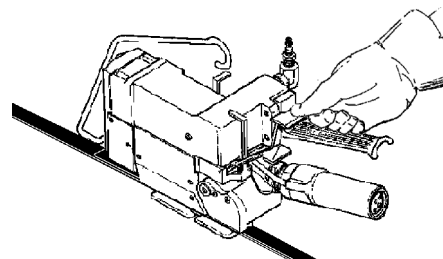

PART REMOVAL, REPLACEMENT & TOOL ADJUSTMENTS

The following procedures describe only the areas of the PHT which require specific maintenance instruction. Basic disassembly procedures are not covered within the context of this manual in order to avoid any unnecessary labor.

STRAP TENSION

Strap tension is controlled by setting of the adjusting screw. Use proper air line piping and lubricant as specified in this manual. A minimum of 70 psig (4.8 bar) is required to ensure that the tool will operate properly.

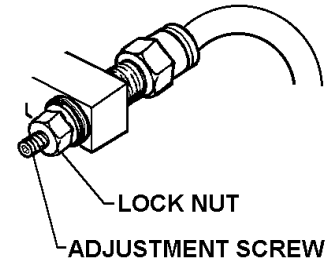

Adjust strap tension as follows:

1. Make sure the air pressure is set between 70 and 90 psig (4.8 - 6.2 BAR).
2. Loosen the lock nut which secures the adjustment screw's position.
3. Turn the adjustment screw in 1/4 turn increments clockwise to decrease tension and counterclockwise to increase tension.

⚠ WARNING

Strap breakage hazard. Increasing the tension can result in strap breakage and could cause personal injury. Never remove the adjusting screw from the tool with the air connected. The screw could become a flying projectile.

NOTE: Maximum strap tension levels depend on the size strap being used. See page 5, Tool Specifications for information on strap tension levels.

4. Run a test cycle to check the new adjustment. Continue to adjust strap tension if necessary.

WELD COOL-TIME ADJUSTMENT

Turn the adjustment screw found on the side of the tool clockwise to increase weld cool time. Turn the adjustment screw counter-clockwise to decrease weld cool time. Turn the adjustment screw in 1/4 turn increments

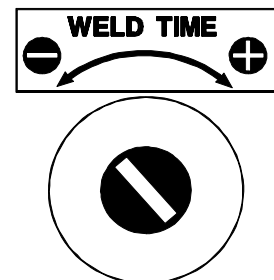

FEEDWHEEL REPLACEMENT

1. To replace the feedwheel, remove the two socket head cap screws which secure the outer link.
2. Remove the outer link from the gear housing.
3. Slide the old feedwheel off the feedwheel shaft. Slide the new feedwheel on to the shaft.
4. Replace the outer link.

NOTE: After replacing the feedwheel it may be necessary to check the feedwheel clearance as described below.

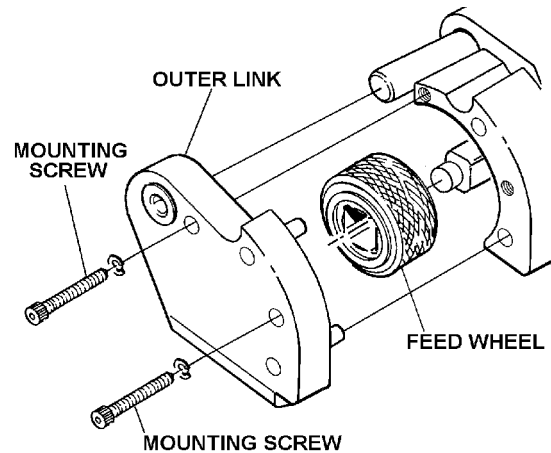

FEEDWHEEL CLEARANCE

The feedwheel clearance to the tension plug must be properly maintained to prevent the feedwheel from slipping on the strap during tensioning. A feedwheel with excessive clearance may result in the feedwheel milling the strap. A feedwheel clearance set too tight may result in damage to the feedwheel and/or the tension plug. Adjust the feedwheel clearance as needed using the steps below:

1. Raise the feedwheel using the air motor as a handle and place 1 to layers of .003, 1/2" wide (.07 x 12mm) shim stock between the feedwheel and tension plug.

NOTE: Use of a single shim is not recommended because a single thicker shim may not conform to the feedwheel shape, resulting in inaccurate clearance measurement.

2. Release the feedwheel to pinch the shims between the feedwheel and the tension plug. Holding the shims with one hand, jog the air motor on and off to rotate the feedwheel at least one full revolution. If properly adjusted the tool should lightly tug at the shims while rotating. Clearance between the feedwheel and tension plug at this point should fall between .003" - .010" (.07-.25mm).

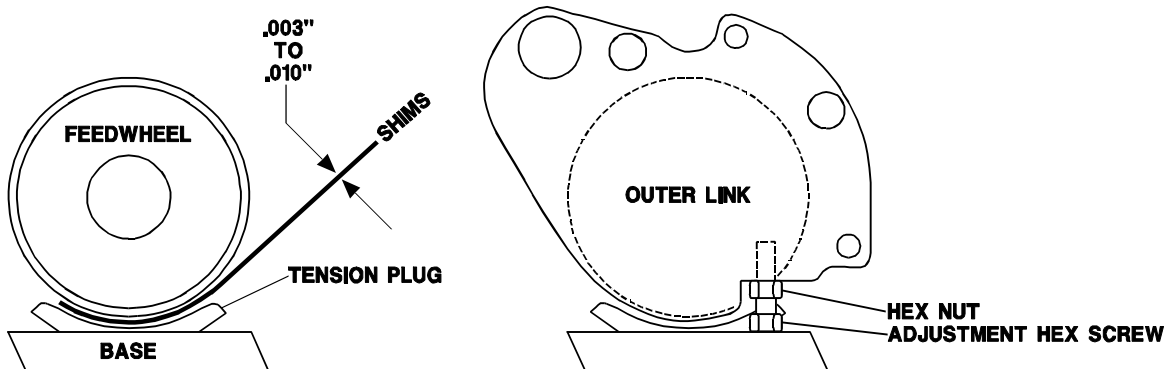

3. If the feedwheel needs to be adjusted, first loosen the hex nut which secures the adjustment screw found on the outer link. Turn the adjustment screw inward for less clearance and outward to increase clearance. Turn the adjustment screw only in 1/8 turn increments. After each 1/8 turn, repeat the adjustment test as described in Step 2.
4. Once the proper clearance has been found, lock the adjustment screw in place using the hex nut.

PART LIST, VALVE ASSEMBLY

<u>KEY</u>	<u>QTY</u>	<u>PART NO.</u>	<u>DESCRIPTION</u>
1	1	423224	MOTOR HOUSING
2	1	423271	CAM MOTOR
3	1	423267	HANDLE
4	1	422181	SUPPORT BLOCK
5	1	422349	CATCH PAWL
6	1	422146	VALVE LEVER (SEALER)
7	1	422180	VALVE LEVER (TENSION)
8	1	422178	LEVER PIN
9	1	422359	CATCH LINK
10	1	306651	VALVE STEM (TENSION)
11	1	422147	VALVE STEM (SEALER)
12	1	306650	VALVE SLEEVE (TENSION)
13	1	422145	VALVE SLEEVE (SEALER)
14	1	306683	CATCH PIN
15	1	422351	SPRING SOCKET
16	1	256728	NEEDLE BEARING, INA #HK-1012
17	1	422655	COMPRESSION SPRING, LEE #LC-014A-13
18	1	306778	COMPRESSION SPRING, LEE #LC-020A-4
19	1	306776	COMPRESSION SPRING, LEE #LC-026D-3
20	1	306734	RUBBER BALL 3/8" DIA.
21	2	092772	O-RING, #2-014
22	1	004164	O-RING, #2-011
23	1	306741	COMPRESSION SPRING, LEE #LC-042G-5
24	1	306733	RUBBER BALL 5/8" DIA.
25	2	022789	O-RING, #2-016
26	1	097529	O-RING, #2-111
27	3	256970	SHCS, M4 X 25
28	6	165392	SHCS, M5 X 30
29	3	187415	SPLIT LOCK WASHER - M5
30	1	286373	INFORMATION SIGN (3-ICON)
31	1	422188	WARNING SIGN
32	1	436110	NAME PLATE (PHT-16)
	1	436122	NAME PLATE (PHT-19)
33	1	422757	SCREEN
34	1	070433	STREET ELBOW 1/4"
36	1	171661	STEEL COLLAR
37	1	020704	HANSEN PLUG, 1/4 - 18
38	1	008798	TAG
54	1	016148	PIPE NIPPLE, 1/8
75	1	171655	NYLON LOCKWASHER
81	7	028081	SHCS, M5 X 12
82	2	162383	SHCS, M4 X 6
83	2	162382	SPLIT LOCK WASHER, M4
117	1	422393	TUBING
118	1	422693	ADJUSTMENT BLOCK
119	1	024714	ADJUSTMENT SCREW
120	1	059918	HEX NUT, 5/16-18
121	2	422396	MUFFLER
122	1	422357	MUFFLER COVER

! When ordering parts, please show tool model, part number and description.
! Standard hardware parts may be obtained from any local hardware supply.

KEY	QTY	PART NO.	DESCRIPTION
124	1	423583	ELBOW
126	1	423593	TUBING
180	1	436109	INFORMATION SIGN
192	1	423850	ADJUSTMENT SCREW
193	1	423851	PLUG
194	1	306496	SPRING, LEE #LHL-375B-4
246	1	422696	CONNECTOR

! When ordering parts, please show tool model, part number and description.
! Standard hardware parts may be obtained from any local hardware supply.

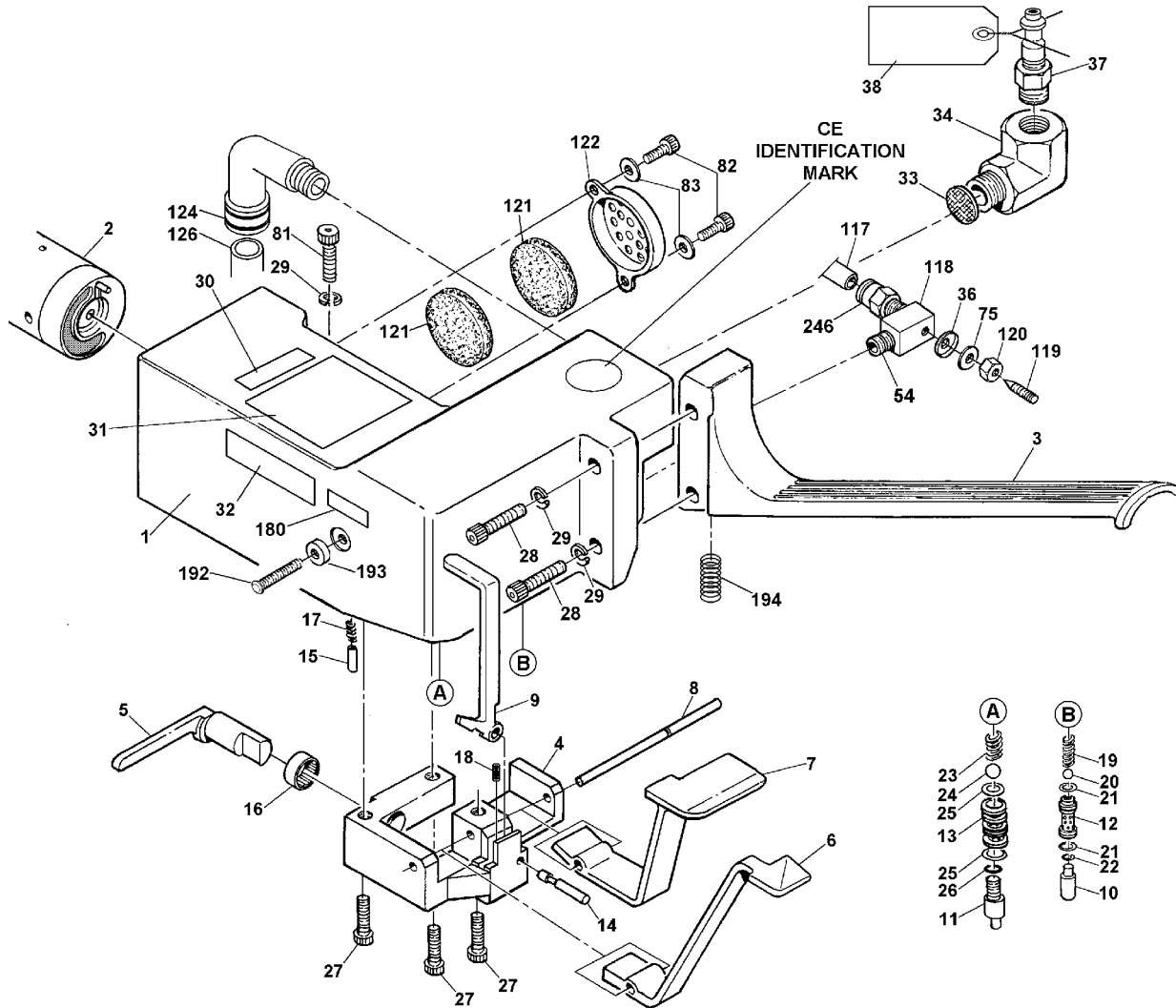

WARNING
Inspect all parts daily and replace them if they are worn or broken. Failure to do this can affect a product's operation and could result in serious personal injury.

PARTS LIST, GEAR HOUSING ASSEMBLY

<u>KEY</u>	<u>QTY</u>	<u>PART NO.</u>	<u>DESCRIPTION</u>
29	8	187415	SPLIT LOCK WASHER, M5
35	5	171689	SHCS
39	1	422154	GEAR CASE COVER
40	1	423225	SEALER GEAR CASE
41	1	422156	GEAR, DRIVE
42	1	306443	PINION
43	1	306442	GEAR
44	1	306429	DOWEL PIN, M 3 X 22MM
45	1	422656	NEEDLE BEARING, INA #HK-0810
47	1	422666	DOWEL PIN, M1.5X6
48	1	306328	NEEDLE BEARING, INA #BK-0810
49	1	306329	NEEDLE BEARING, INA #BK-1512
50	1	422657	NEEDLE BEARING, INA #BK-1015
145	3	010072	SHCS, M5 x 50
157	3	423263	SPACER
158	1	423268	HANGER
249	1	423227	SPACER

! When ordering parts, please show tool model, part number and description.

! Standard hardware parts may be obtained from any local hardware supply.

** Secure with Loctite #609.

*** Lubricate with Molith No. 2 or Lubriplate 3000W.

NOTE-1: Orient Ring Gear (Key 312, Sealer Motor 422391) as shown to align notch with Dowel pin (Key 47) during assembly of the gear housing to the motor housing.

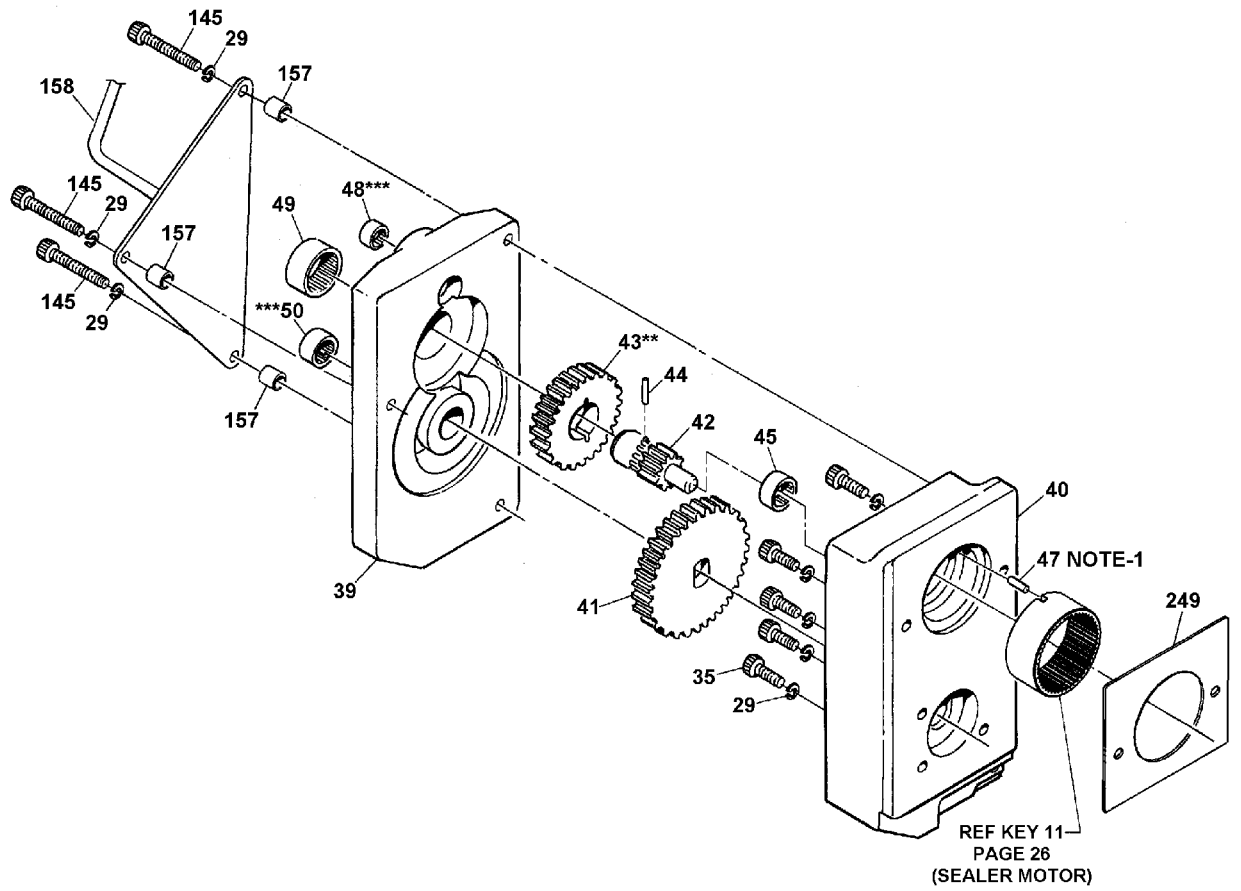

⚠ WARNING

Inspect all parts daily and replace them if they are worn or broken. Failure to do this can affect a product's operation and could result in serious personal injury.

PARTS LIST, SEALER MECHANISM ASSEMBLY

<u>KEY</u>	<u>QTY</u>	<u>PART NO.</u>	<u>DESCRIPTION</u>
29	7	187415	M5 SPLIT LOCK WASHER
46	1	422641	BEARING
53	1	424199	HOUSING
55	1	423168	CAM SHAFT
56	1	423191	DIE COVER
57	1	423174	VIBRATOR GUIDE
58	1	423211	GRIPPER LIFTER
59	1	423182	VIBRATOR GR HOUSING
60	1	423213	TENSION PLUG
61	1	423196	LIFTER
62	1	423198	MIDDLE GUIDE
63	2	422144	CAM FOLLOWER
64	2	306030	FOLLOWER PIN
65	1	423175	STRAP DEFLECTOR
66	1	423179	CUTTER
67	1	423181	FRONT GRIPPER HOUSING
68	1	424346	CAM
69	1	423190	BACK GRIPPER
70	1	424198	FRONT GUIDE HOUSING
71	1	424197	FRONT GUIDE
72	1	423251	FRONT GUIDE SPACER
73	1	423180	FOLLOWER HOUSING
74	1	423202	GRIPPER PAD
	1	424260	GRIPPER PAD (Optional - for round or irregular packages)
76	3	164618	SHCS M5 X 8
77	1	423209	LOWER PAD Z
78	1	423212	DROP HANDLE
83	4	162382	M4 SPLIT LOCK WASHER
84	1	423194	GRIPPER ARM
88	1	424187	BACK GUIDE
127	1	423580	TORR B-810
128	8	423584	BELLEVILLE SPRING WASHER B1000-073
130	1	423586	LEE SPRING LC-035C-4
131	1	423587	LEE SPRING LC-016A-2
132	1	423588	LEE SPRING LE-041C-7
133	1	020725	LEE SPRING
134	1	422804	LEE SPRING
135	1	253596	DOWEL PIN 6 X 14
136	1	424007	VIBRATOR ROLLER
137	1	004908	DOWEL PIN .187 DIA X 1.750
138	1	423589	DOWEL PIN 4 X 40
139	1	424003	DOWEL PIN 4 X 16
140	1	023962	INFO SIGN
141	1	424575	SPRING SCREW
142	5	423591	SHCS M4 X 5
144	4	280582	M4 LOCKWASHER (HIGH COLLAR)
147	1	306047	SS M5 X 5
149	1	023438	TRUARC N5000-50 (1/2" INTERNAL)
150	1	423592	M8 HEX NUT
151	1	269582	3/16 X 1/4 DOWEL PIN
152	1	171044	BOLT
153	1	423587	LEE SPRING LC-016A-2
154	1	251262	SHSS M8 X 6
155	4	028081	SHCS M5 X 12
156	1	436108	INFORMATION SIGN
157	1	010029	FHSS M5 X 16
158	1	438659	FHCS M4 X 8
159	5	423855	DOWEL PIN 3 X 10

WARNING

Inspect all parts daily and replace them if they are worn or broken. Failure to do this can affect a product's operation and could result in serious personal injury.

KEY	QTY	PART NO.	DESCRIPTION
190	1	424272	SPRING HOLDER
191	1	181261	PIN, M5 X 10
195	1	423854	BELLVILLE SPRING WASHER MB1000-050
196	1	010077	M6 SPLIT LOCKWASHER
197	1	306622	BEARING, TORR-B-86
198	4	423590	ROLL PIN
199	4	306079	M4, SPLIT LOCKWASHER (THICK)
200	1	424002	ROLL PIN, 5/64 X 1 (TRIM TO FIT)
240	1	424009	PAD SHIM
241	1	424006	ROLLER HOLDERS
247	2	256791	PIN, 5 X 14

NOTES:

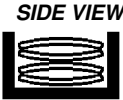
- Assemble spring washers (128,195) back-to-back for maximum height. 
- Replacement cams are stamped with number "15" on one side. Install cam (Key 68) as shown with number "15" facing away from cam shaft (Key 55).

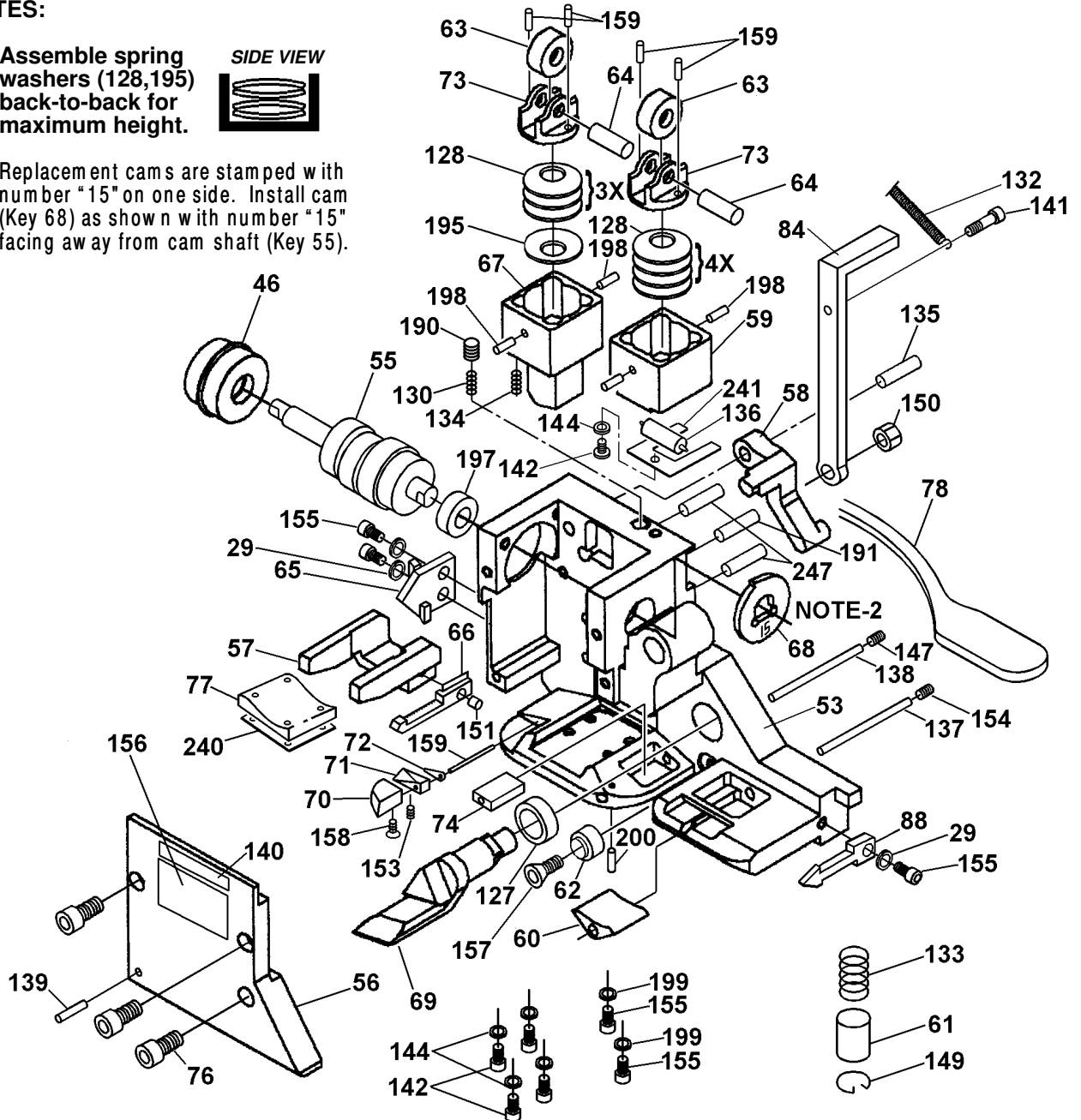

PARTS LIST, TENSIONER ASSEMBLY

<u>KEY</u>	<u>QTY</u>	<u>PART NO.</u>	<u>DESCRIPTION</u>
29	2	187415	SPLIT LOCKWASHER, M5
51	2	171689	SHCS, M5 X 18
89	1	423185	GEAR HOUSING
90	1	423188	OUTER LINK
<u>92</u>	<u>1</u>	<u>423184</u>	<u>FEEDWHEEL</u>
93	1	306694	PIVOT SHAFT
95	1	424327	GEAR SET
97	1	306692	BEARING COVER
98	1	423186	FEEDWHEEL SHAFT
102	5	000884	WOODRUFF KEY
103	2	256747	SHCS, M4 X 16
104	1	256755	O-RING, # 2-030
105	1	306770	NEEDLE BEARING, INA #BK1712
107	1	020158	BALL BEARING, FAFNIR #7201K
<u>109</u>	<u>1</u>	<u>306767</u>	<u>DU FLANGE BEARING, FMB #1217-DU</u>
110	2	162404	DOWEL PIN, M6 X 28
111	1	306768	INNER RING, INA #IR12X16X16
113	1	306766	THRUST NEEDLE CAGE
114	1	306769	NEEDLE BEARING, INA #HK1712
115	1	306782	SEAL, INA # GR17X23X3
116	2	306772	NEEDLE BEARING, INA #BK1212
123	1	424423	TENSION MOTOR (PHT-16)
	1	424150	TENSION MOTOR (PHT-19)
242	2	422659	THRUST WASHER, INA #AS1730
243	1	423254	FEEDWHEEL SPACER
244	1	424067	HEX NUT
245	1	424066	HEX BOLT

- ! When ordering parts, please show tool model, part number and description.
- ! Standard hardware parts may be obtained from any local hardware supply.
- ! Wearing parts are usually limited to those underlined and should be stocked.

⚠ WARNING

All parts must be periodically inspected and replaced if worn or broken. Failure to do this can affect a product's operation and can result in personal injury.

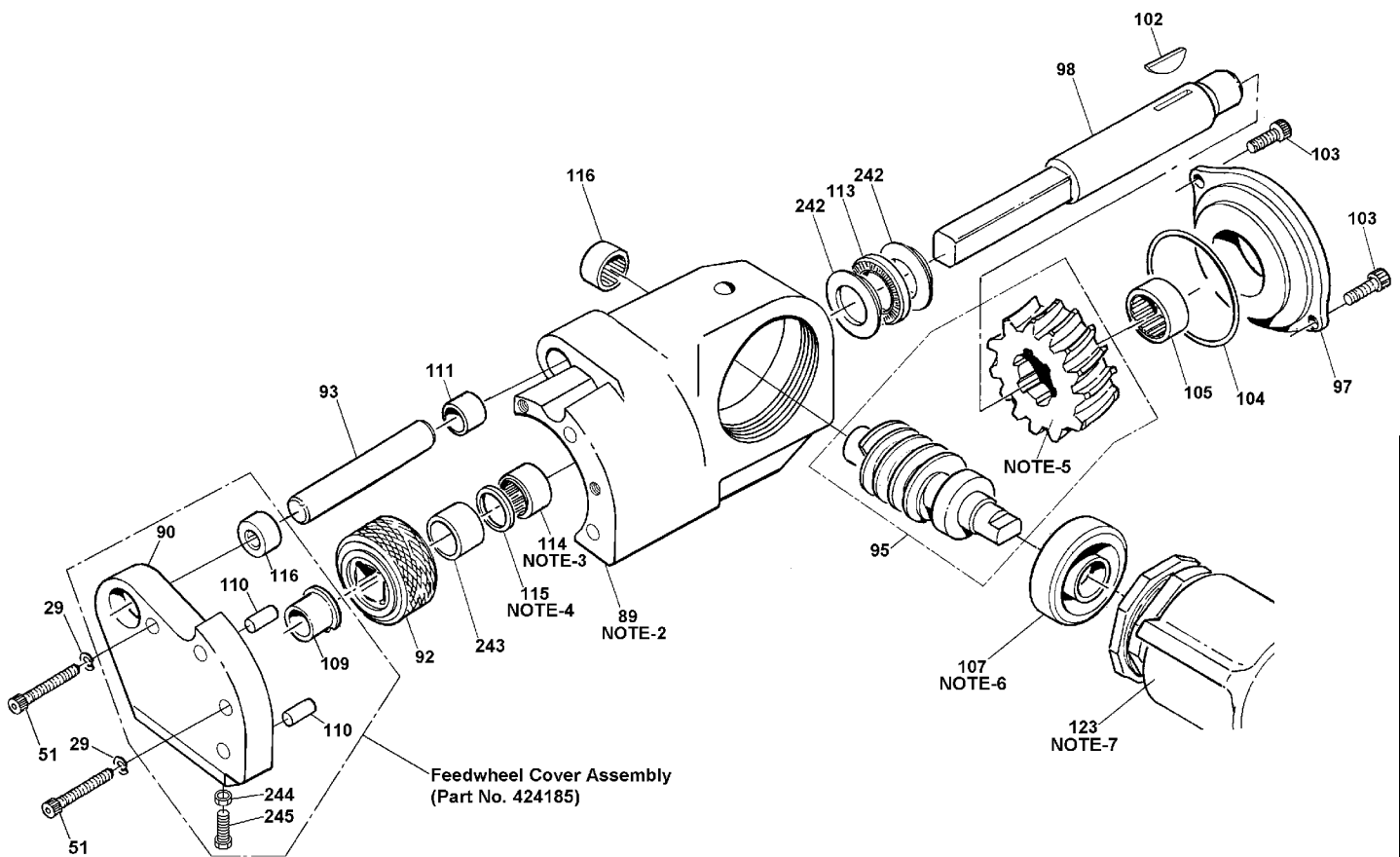

NOTES:

1. Use Teflon tape.
2. Fill the gear housing 1/3 full with Non-Fluid Oil #55 (Non-Fluid Oil company or equivalent).
3. Install Key numbers 114 & 115 into gear housing (Key 89) using Loctite Bearing Mount #609.
4. Install Key 115 with the flat side facing outwards from gear housing.
5. Install Key 99 with shoulder facing outwards from gear housing.
6. Install Key 107 with the beveled edge facing outwards from gear housing.
7. When mounting Key 123 to the gear housing align the tube hole with the edge of the housing.

PARTS LIST, VIBRATOR MOTOR ASSEMBLY

<u>KEY</u>	<u>QTY</u>	<u>PART NO.</u>	<u>DESCRIPTION</u>
35	4	171689	SHCS, M5 X 18
82	2	162383	SHCS, M4 X 6
83	2	162384	M4 SPLIT LOCKWASHER
121	1	422396	MUFFLER
122	1	422357	MUFFLER COVER
128	1	423584	BELLEVILLE SPRING WASHER B1000-073
132	1	423588	LEE SPRING, LE-041C-7
146	1	424575	SPRING SCREW
155	2	028081	SHCS, M5 X 12
160	1	424290	BEARING, GENERAL BEARING CORP #R8-2RS
161	1	424291	BEARING, TORRINGTON #JTT-610
162	2	094295	O-RING .312 X .187 X .062 THK SAE 8
163	1	024661	SPRING
164	1	092044	O-RING 1.625 1.500 0.062 THK SAE 29
165	2	020699	O-RING .562 X .437 X .062 THK SAE 13
166	1	256755	O-RING 1.75 1.625 0.062 THK SAE 30
<u>167</u>	<u>1</u>	<u>269570</u>	<u>HOLLOW PIN</u>
168	1	306831	VALVE SLEEVE
169	1	306838	RETAINING RING, SMALLEY # VH-56 OR EQUIV.
170	1	423195	VALVE STEM
172	1	424285	ADAPTER MOTOR HOUSING
173	1	423173	VIBRATOR ARM
174	1	423208	VIBRATOR PAD Z
175	1	423210	MOTOR COVER
176	1	424175	VIBRATOR MOTOR (ALTERNATE P/N 423272)
177	1	424289	BEARING, GENERAL BEARING CORP #R4A-2RS
178	3	423582	CAMOZZI 6700-5 CARTRIDGE
179	1	423593	HOSE
181	1	423171	ECCENTRIC SHAFT
187	20	187415	SPLIT LOCK WASHER, M5
199	2	306079	M4 LOCKWASHER (HIGH COLLAR)
200	1	269583	FELT
247	3	181261	PIN, 5 X 12
248	1	424281	BEARING SUPPORT

- ! When ordering parts, please show tool model, part number and description.
- ! Standard hardware parts may be obtained from any local hardware supply.
- ! Wearing parts are usually limited to those underlined and should be stocked.

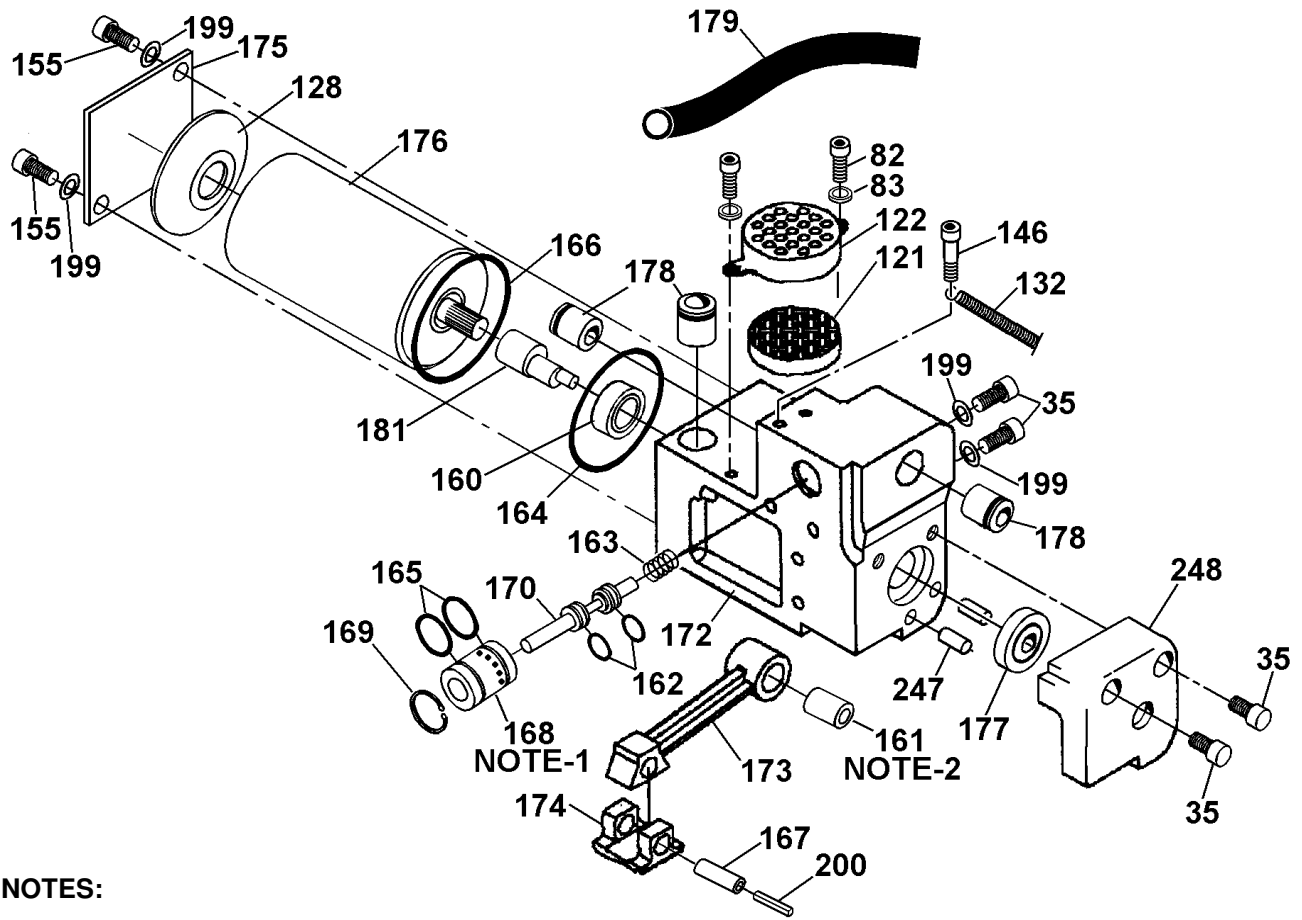

NOTES:

1. Valve sleeve (Key 168) must be installed with vent holes facing housing.
2. Bearing (Key 161) must be installed centered within the vibrator arm (Key 173).

ALTERNATE VIBRATOR COMPONENTS

<u>KEY</u>	<u>QTY</u>	<u>PART NO.</u>	<u>DESCRIPTION</u>
160	1	424252	BEARING, TORR J-88
172	1	423170	ADAPTER MOTOR HOUSING
177	1	424253	BEARING, TORR MJ-471

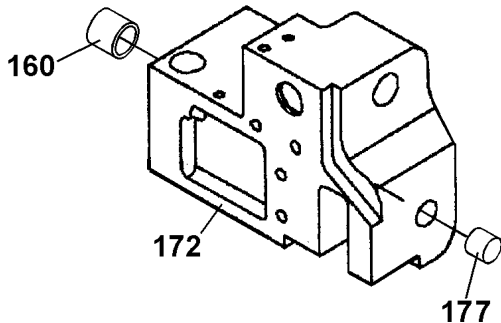

PARTS LIST, TENSIONER MOTOR, 424423

NOTE: This air motor can be identified by the letters ITW stamped in the housing by the air inlet.

<u>KEY</u>	<u>QTY</u>	<u>PART NO.</u>	<u>DESCRIPTION</u>
401	1	424166	LOCK NUT
402	1	164969	RETAINING RING, N5000-118
403	1	023547	BALL BEARING
404	1	424159	IDLER CARRIER
405	6	422869	IDLER GEAR
406	1	424153	MOTOR GEAR HOUSING
407	2	090065	LOCK PIN
408	2	422870	RING GEAR
401	2	423151	ADAPTER PLATE
411	2	014541	BELLEVILLE SPRING WASHER, B1250-062
412	1	424157	SPACER
413	1	306396	BALL BEARING
414	1	423892	IDLER CARRIER
418	1	023481	BALL BEARING
419	1	424155	FRONT END PLATE
420	1	424424	ROTOR
421	5	422818	VANE
422	1	422815	CYLINDER
423	2	424164	SPRING PIN, 2.5 X 10
424	1	424154	BACK END PLATE
425	1	424161	BALL BEARING
426	2	424172	O-RING, SAE 125
427	1	424152	MOTOR HOUSING ASSEMBLY
428	1	424167	MUFFLER INSERT
429	1	424165	MUFFLER PLATE
430	1	424162	TRUARC, N5000-145

- ! When ordering parts, please show tool model, part number and description.
- ! Standard hardware parts may be obtained from any local hardware supply.
- ! Wearing parts are usually limited to those underlined and should be stocked.

NOTES:

1. Apply high strength retaining compound to inner diameter and outer diameter of ball bearing (Key 425).
2. Maintain a .002 clearance between back end plate (Key 424) and rotor (Key 420).

WARNING

Inspect all parts daily and replace them if they are worn or broken. Failure to do this can affect a product's operation and could result in serious personal injury.

**AIR MOTOR
IDENTIFICATION
PART NUMBER
&
SERIAL NUMBER**

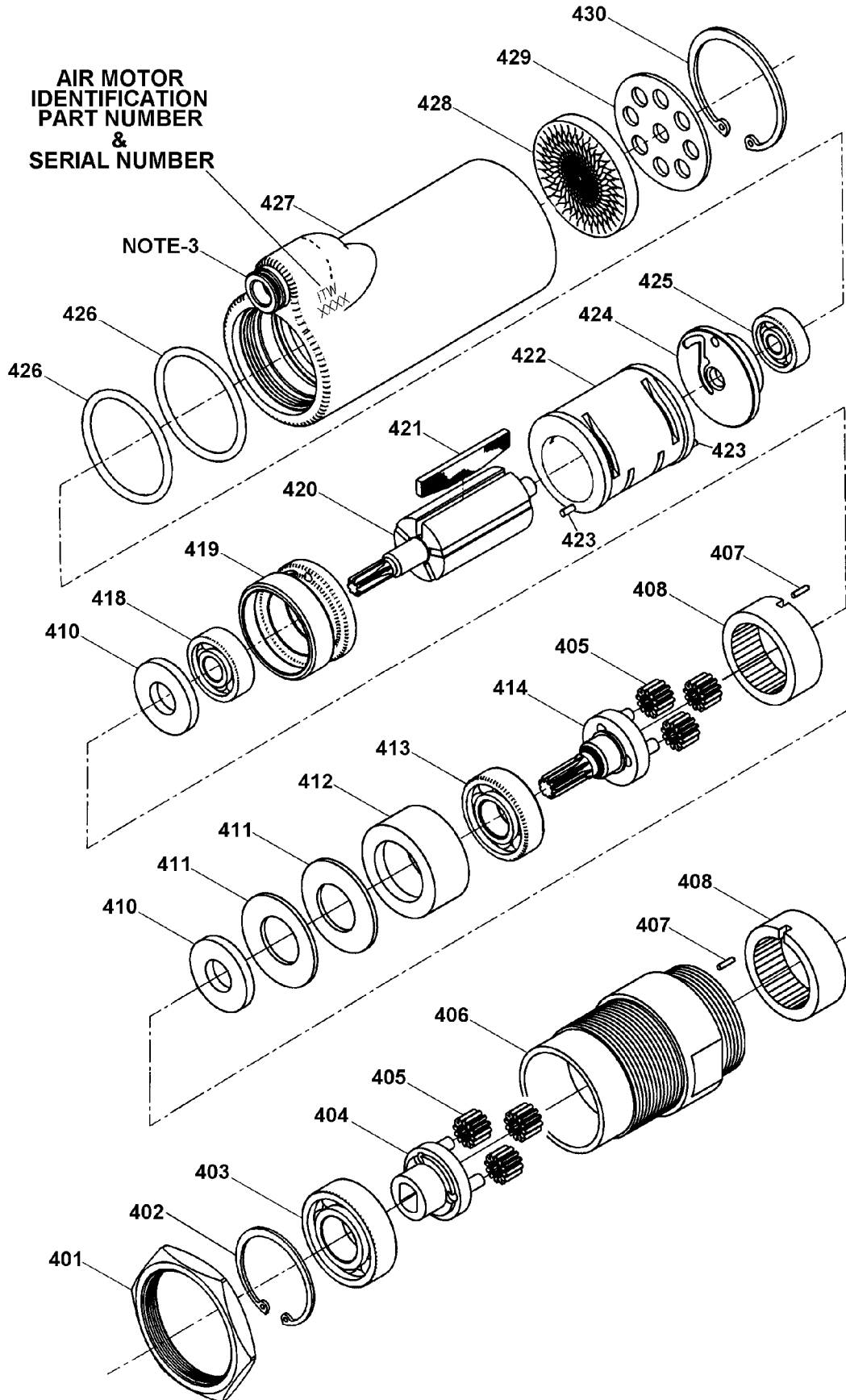

PARTS LIST, TENSIONER MOTOR, 424150

NOTE: This air motor can be identified by the letters ITW stamped in the housing by the air inlet.

<u>KEY</u>	<u>QTY</u>	<u>PART NO.</u>	<u>DESCRIPTION</u>
401	1	424166	LOCK NUT
402	1	164969	RETAINING RING, N5000-118
403	1	023547	BALL BEARING
404	1	424159	IDLER CARRIER
405	3	422869	IDLER GEAR
406	1	424153	MOTOR GEAR HOUSING
407	2	090079	LOCK PIN
408	1	422870	RING GEAR
401	2	423151	ADAPTER PLATE
411	2	014541	BELLEVILLE SPRING WASHER, B1250-062
412	1	424157	SPACER
413	1	306396	BALL BEARING
414	1	424158	IDLER CARRIER
416	3	024604	IDER GEAR ASSEMBLY
417	1	024608	RING GEAR
418	1	023481	BALL BEARING
419	1	424155	FRONT END PLATE
420	1	424156	ROTOR
421	5	422818	VANE
422	1	422815	CYLINDER
423	2	424164	SPRING PIN, 2.5 X 10
424	1	424154	BACK END PLATE
425	1	424161	BALL BEARING
426	2	424172	O-RING, SAE 125
427	1	424173	MOTOR HOUSING ASSEMBLY
428	1	424167	MUFFLER INSERT
429	1	424165	MUFFLER PLATE
430	1	424162	TRUARC, N5000-145

- ! When ordering parts, please show tool model, part number and description.
- ! Standard hardware parts may be obtained from any local hardware supply.
- ! Wearing parts are usually limited to those underlined and should be stocked.

NOTES:

1. Apply high strength retaining compound to inner diameter and outer diameter of ball bearing (Key 425).
2. Maintain a .002 clearance between back end plate (Key 424) and rotor (Key 420).

▲WARNING

Inspect all parts daily and replace them if they are worn or broken. Failure to do this can affect a product's operation and could result in serious personal injury.

**AIR MOTOR
IDENTIFICATION
PART NUMBER
&
SERIAL NUMBER**

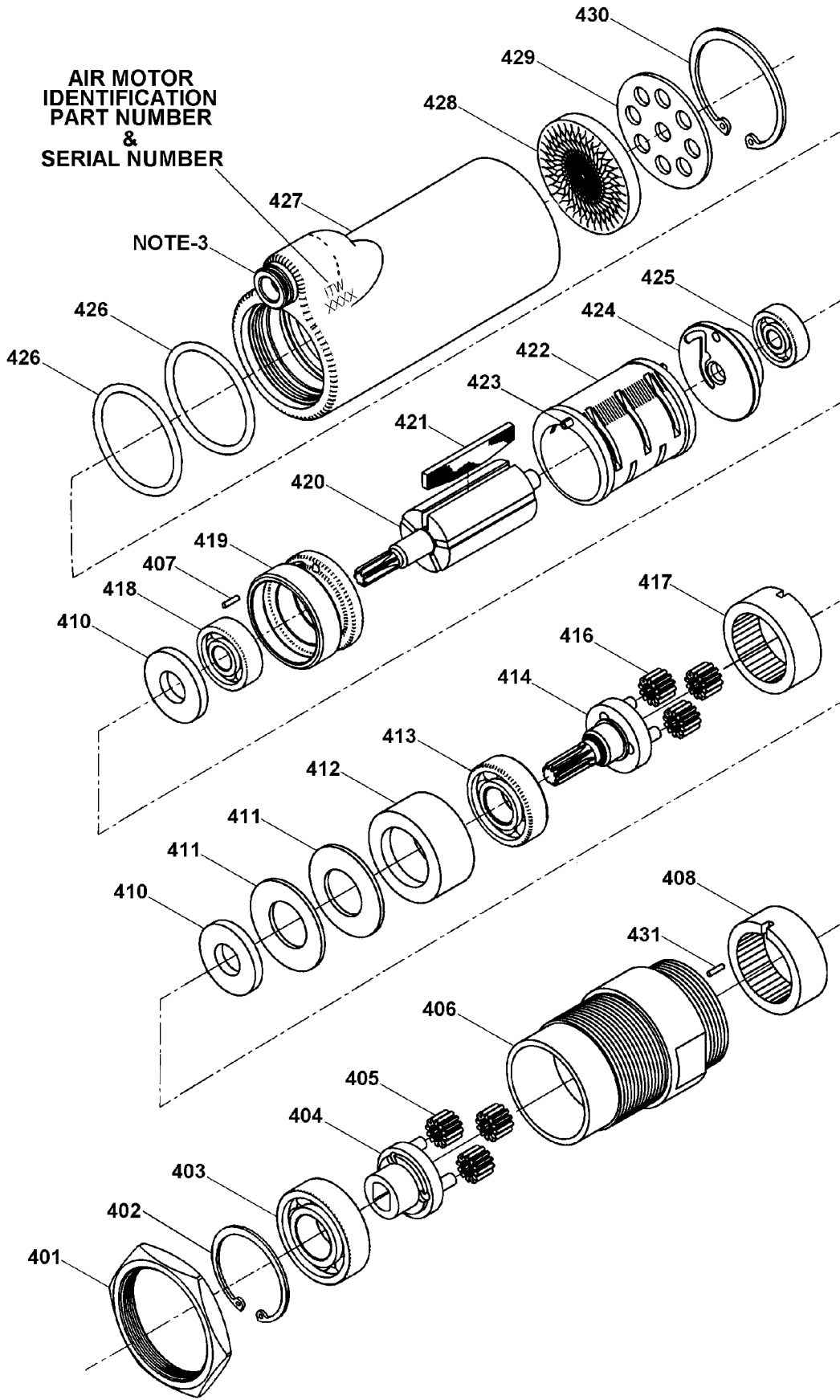

PARTS LIST, TENSIONER MOTOR, 422394 (ALTERNATE)

<u>KEY</u>	<u>QTY</u>	<u>PART NO.</u>	<u>DESCRIPTION</u>
106	1	306656	BEARING SLEEVE
108	1	164969	RETAINING RING
201	1	422634	RETAINING RING,TRUARC #N5000-150-S-PP
202	1	422612	COVER
203	1	422397	MUFFLER
204	1	422613	DEFLECTOR
205	1	422614	MOTOR HOUSING
206	2	092043	O-RING, #2-125
207	1	250300	BEARING, FAFNIR #36KDD
<u>208</u>	<u>1</u>	<u>422615</u>	<u>REAR END PLATE</u>
209	1	422616	CYLINDER ASSEMBLY
<u>210</u>	<u>5</u>	<u>422617</u>	<u>VANE</u>
211	1	422618	ROTOR
<u>212</u>	<u>1</u>	<u>422619</u>	<u>FRONT END PLATE</u>
213	1	006554	BEARING, FAFNIR #38KDD
214	1	422620	SPACER
215	3	023097	BEARING, FAFNIR #9101K-FS118
216	2	422621	SHAFT
217	2	422622	PLANET ASSEMBLY
218	1	422623	SPINDLE
219	2	422624	SPACER
220	1	422625	GEAR CASE
221	1	422635	RETAINING RING,TRUARC #N5000-131-S-PP
222	1	422626	SPACER
223	3	422627	PIN
224	1	422628	GEAR
225	3	422637	PLANET GEAR ASSEMBLY
227	1	422631	SPINDLE
228	1	422632	SPACER
229	1	422633	GEAR CASE
230	1	264313	BEARING, FAFNIR #9102K-FS118
231	1	422150	LOCK NUT

- ! When ordering parts, please show tool model, part number and description.
- ! Standard hardware parts may be obtained from any local hardware supply.
- ! Wearing parts are usually limited to those underlined and should be stocked.

NOTES:

1. Thread Gear Case (Key 220) into Motor Housing (Key 205) and torque to 10-12 foot-pounds (14-16Nm).
2. Thread Gear Case (Key 229) onto Gear Case (Key 220) and torque to 35-40 foot-pounds (47-54Nm).



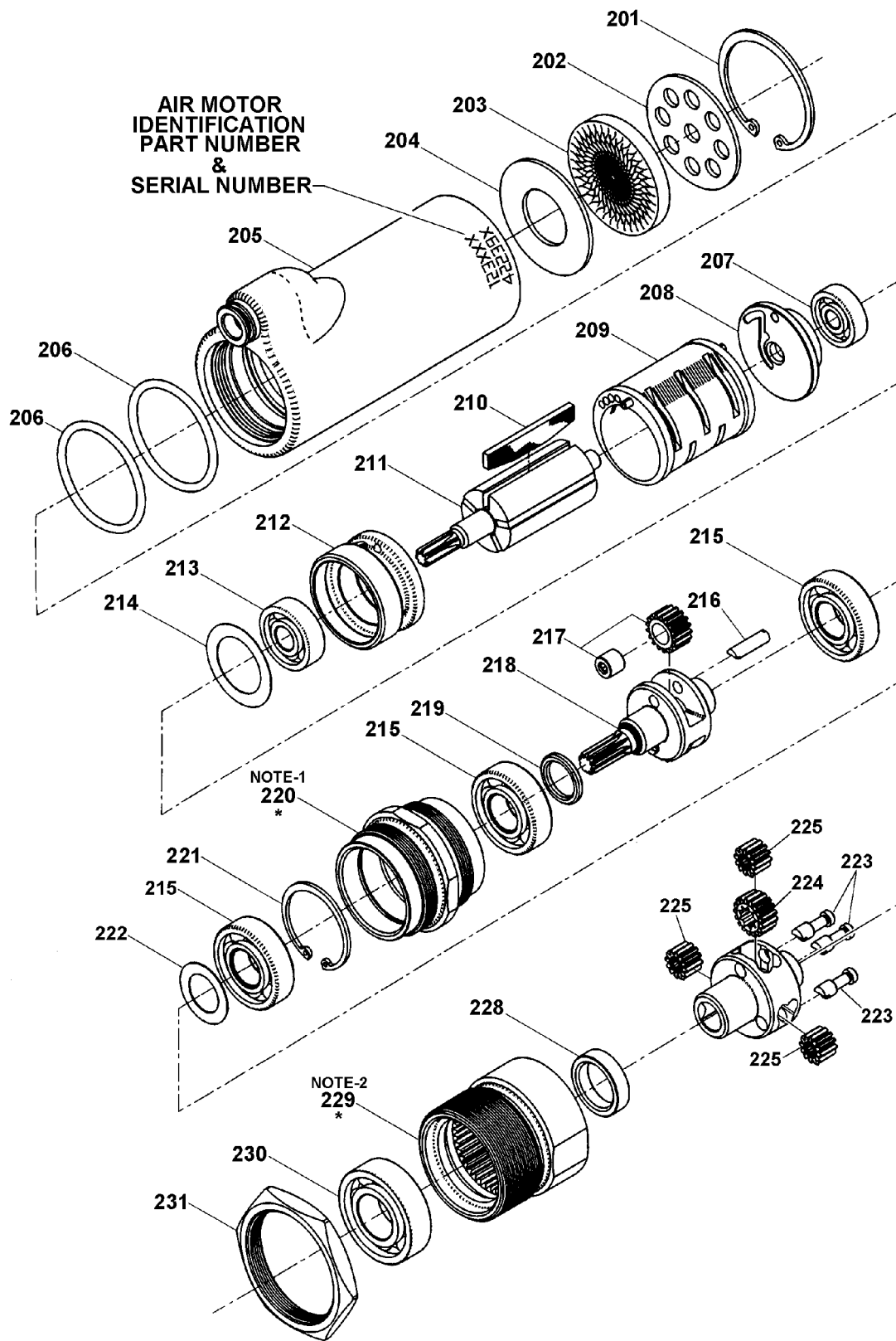

* Use Loctite #271.

PARTS LIST, VIBRATOR MOTOR, 423272

<u>KEY</u>	<u>QTY</u>	<u>PART NO.</u>	<u>DESCRIPTION</u>
351	1	423778	BEARING
352	1	423779	FRONT END PLATE
353	5	423780	VANE
354	1	423781	ROTOR
355	1	423782	CYLINDER
356	1	423783	BUSHING
357	1	423784	BACK END PLATE
358	1	423785	BEARING
359	1	423786	SCREW
360	1	423787	END CUP

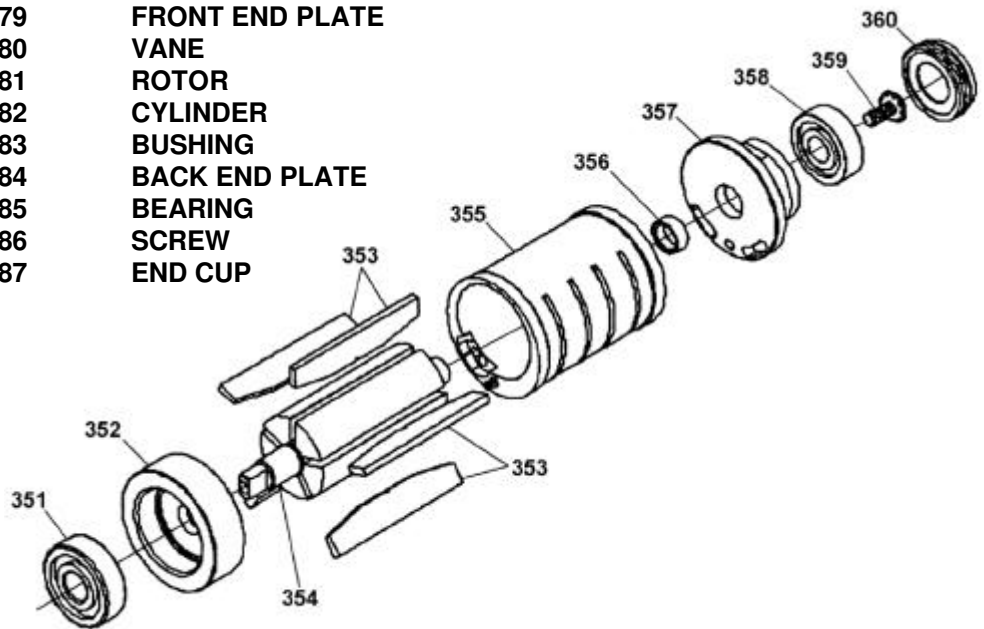

PARTS LIST, VIBRATOR MOTOR, 424175

<u>KEY</u>	<u>QTY</u>	<u>PART NO.</u>	<u>DESCRIPTION</u>
1	2	014730	BELLEVILLE SPRING
2	1	424176	BACK END PLATE
3	1	024633	BALL BEARING
4	2	004998	SPRING PIN, 3/32 X 3/8
5	5	424177	VANE
6	1	424178	ROTOR
7	1	424179	CYLINDER
8	1	024602	SPACER
9	1	424180	FRONT END PLATE
10	1	023481	BALL BEARING
11	1	424181	FLAT WASHER

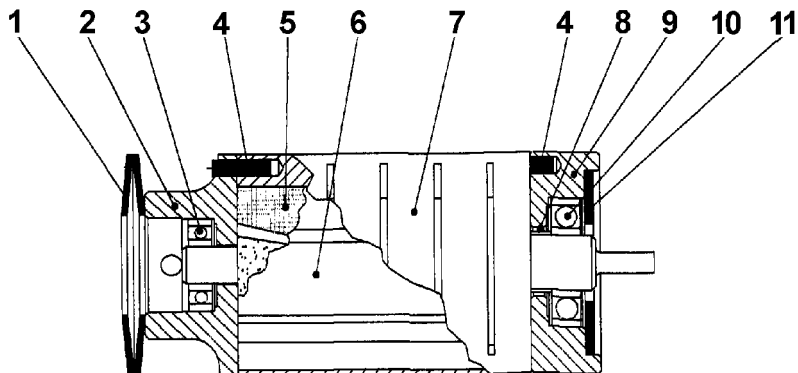

PARTS LIST, CAM MOTOR, 423271

<u>KEY</u>	<u>QTY</u>	<u>PART NO.</u>	<u>DESCRIPTION</u>
1	1	423832	BACK END PLATE
2	1	024633	BALL BEARING
3	1	423833	CYLINDER
4	1	423834	ROTOR
5	1	423835	FRONT END PLATE
6	1	023481	BALL BEARING
7	2	423836	BELLVILLE SPRING
8	1	423837	RING GEAR
9	3	423838	IDLER GEAR
10	1	423839	IDLER CARRIER
11	1	423840	RING GEAR
12	3	423841	IDLER GEAR
13	1	423842	OUTPUT SHAFT
14	1	306396	BALL BEARING
15	1	423843	ALIGNMENT PIN
16	1	024612	VANE
17	1	024602	SPACER
18	6	423844	IDLER PIN
19	2	423845	LOCK PIN
20	1	423846	SET SCREW, M6
21	1	023520	BALL BEARING
22	1	423224	MOTOR HOUSING
23	1	423225	CASE
24	1	423227	SPACER

- ! When ordering parts, please show tool model, part number and description.
- ! Standard hardware parts may be obtained from any local hardware supply.
- ! Wearing parts are usually limited to those underlined and should be stocked.

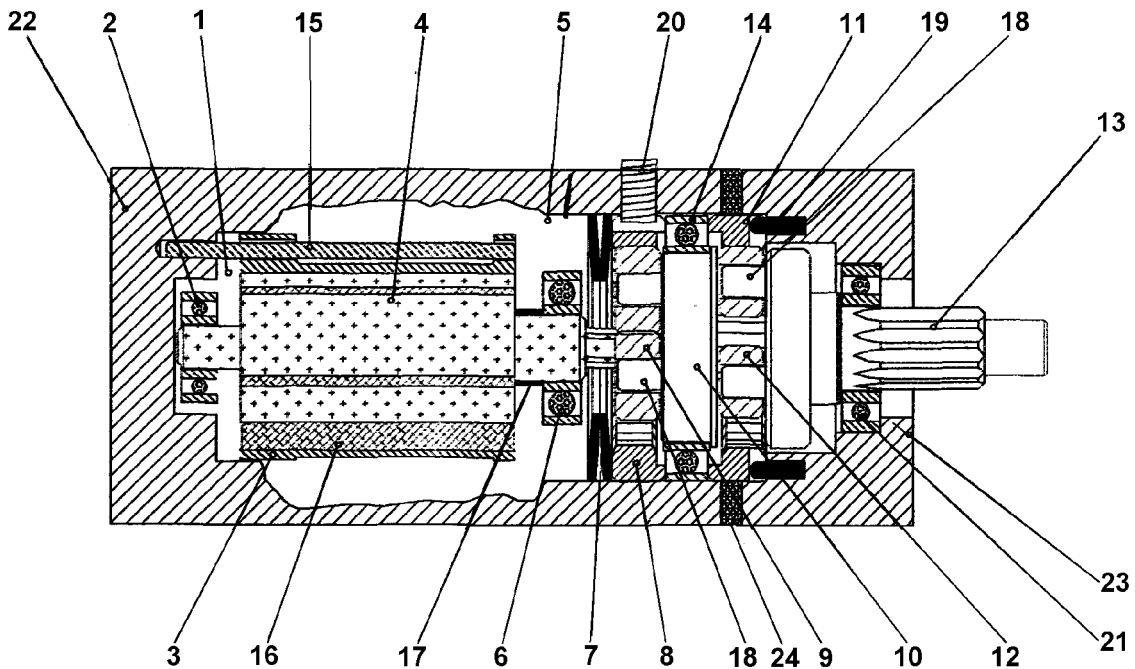

TROUBLESHOOTING

The following items are the most common types of tool malfunctions. For symptoms or remedies not shown, contact your Signode service representative for additional information and details. The following tool conditions are shown in this manual:

- #1 - The air motor is frozen or not starting.
- #2 - Bottom strap slips during tensioning
- #3 - Upper strap slips after cutoff
- #4 - Feedwheel milling on strap
- #5 - Incomplete or no weld
- #6 - Strap is over-welded
- #7 - Strap brakes after cycle is completed

#1 CONDITION: The air motor is frozen or not starting.

CAUSE	REMEDY
1. The motor is dry, hindering it from providing maximum performance.	1. Add several drops of oil into the motors through the air inlet. Depress the operating lever while gently tapping the motor with a rubber mallet. Repeat this procedure several times if necessary.
2. Pressing tension or cycle lever air motor does not start.	2. Open appropriate valve, lubricate motor, run motor,

#2 CONDITION: Bottom strap slips during tensioning

CAUSE	REMEDY
Back gripper is clogged with dirt or strap residue.	Clean teeth on back gripper with the special brush provided or blow it with compressed air.

#3 CONDITION: Upper strap slips after cutoff

CAUSE	REMEDY
Front Gripper dos not hold upper strap under tension..	Decrease tension level. Replace spring washers inside Front Gripper Housing.

#4 CONDITION: Feedwheel milling on strap

CAUSE	REMEDY
3. Feedwheel is clogged with dirt or strap residue.	1. Clean teeth on feedwheel with the special brush provided.
4. Worn teeth on the feedwheel.	2. Replace the feedwheel.

#5 CONDITION: Incomplete or no weld

CAUSE	REMEDY
3. Improperly set cycle time adjustment.	1. Adjust weld time as required per instruction in this manual.
4. Worn teeth on upper or lower gripper.	2. Replace as required.
5. Insufficient air supply pressure.	3. Remedy as required.
6. Worn eccentric shaft or shaft bearing	4. Replace as required.
7. Roller # is lost.	5. Install roller.
8. Worn slider link.	6. Replace as required.

#6 CONDITION: Strap is over-welded

CAUSE	REMEDY
Improper cycle timing adjustment.	Decrease cycle timing as needed.

#7 CONDITION: Strap brakes after cycle is completed

CAUSE	REMEDY
1. Over-welded strap.	1. Decrease cycle timing as needed.
2. Too much tension.	2. Decrease tension as needed.

TOOL MAINTENANCE

The most common reason for poor tool performance and incorrectly formed straps joints is improper tool maintenance. The easiest way to determine if a tool is performing correctly is by inspecting the strap joint. Having a tool maintenance program is a simple task which consists of three parts. First, a quick daily inspection of the tool for any worn or broken parts. Secondly, keep each tool on a schedule of service intervals for cleaning and lubrication. Third, when problems do occur, use the troubleshooting guide to properly determine and fix problems before they lead to more serious tool conditions. Each of these three tasks have been outlined for this particular tool, read and understand all information for improving the life and performance of the tool.

TOOL INSPECTION

Visually inspect the exterior of the tool on a daily basis. Decreased tool life can be prevented by early detection of broken parts. Replace all broken parts with new parts. Review the Parts Removal, Replacement & Adjustments portion of this manual for information and details.

SERVICE INTERVALS

This tool, like most Signode tools, can be used with various sizes of strap which cause different rates of component wear. Also, wear is affected by the environment and tension that the tool applies. In the worst case, heavy gauge wide strapping. All critical moving components of the tool should be inspected at particular intervals, some more often than others. Broken parts can decrease sealing effort, leading to additional component wear and produce lower joint strength.

Inspect the components of the sealing mechanism when:

- A. Joint does not appear as shown in this manual or visually it is detected that the joint is not all formed or formed improperly.
- B. Sealing effort requires higher air pressure or tool is difficult to remove from strap.
- C. When scheduled.

 DANGER If there is any question that joint formation is not as shown or is suspect, it is important that you contact your tool representative immediately.

The feed wheel is subject to wear and chipping. A daily cleaning by brushing off debris will be important to maintaining long life. The first indication of wear will be strap slippage during tensioning. The operator of the tool should be instructed on how to determine when the strap slips during tensioning. Sometimes the teeth need to be cleaned with a wire brush, but if slipping is allowed to continue, the parts will need to be replaced. Using the tool in a dirty environment will increase feedwheel wear.

NOTE: On some Signode tools the feedwheel can be cleaned by holding the tool open in the strap loading position while the tool runs without strap and using a wire brush to clean the feedwheel as it rotates.

Inspect the components of the tensioner mechanism when:

- A. Strap slips when being tensioned.
- B. Evidence of feedwheel milling on the strap face.
- C. When scheduled.

TOOL LUBRICATION

Signode tools use a variety of greases and oils, all of which can be ordered through Signode. When ordering indicate tool model, part number and name.

CHANGING PHT STRAP SIZE

The following table illustrates the unique parts to a particular strap size for the PHT tool. If the strap size of the tool is to be changed, this table must be used to coordinate all the respective parts which must be replaced.

! WARNING

Do not attempt to convert a tools strap size without replacing all of the specified parts for the conversion. Failure to replace all required parts may cause severe personal injury.

UNIQUE PARTS TO PHT STRAP SIZES

KEY	DESCRIPTION	16mm CONFIGURATION	19mm CONFIGURATION
62	Middle Guide	Stepped end of guide must face away housing.	Stepped end of guide must face towards housing.
65	Strap Deflector	Install to display "16"	Install to display "19"
71	Front Guide	Orient parts in the order of #70, #72 & #71.	Orient parts in the order of #70, #71 & 72
88	Back Guide	Narrower slot should face upwards.	Wider slot should face upwards.

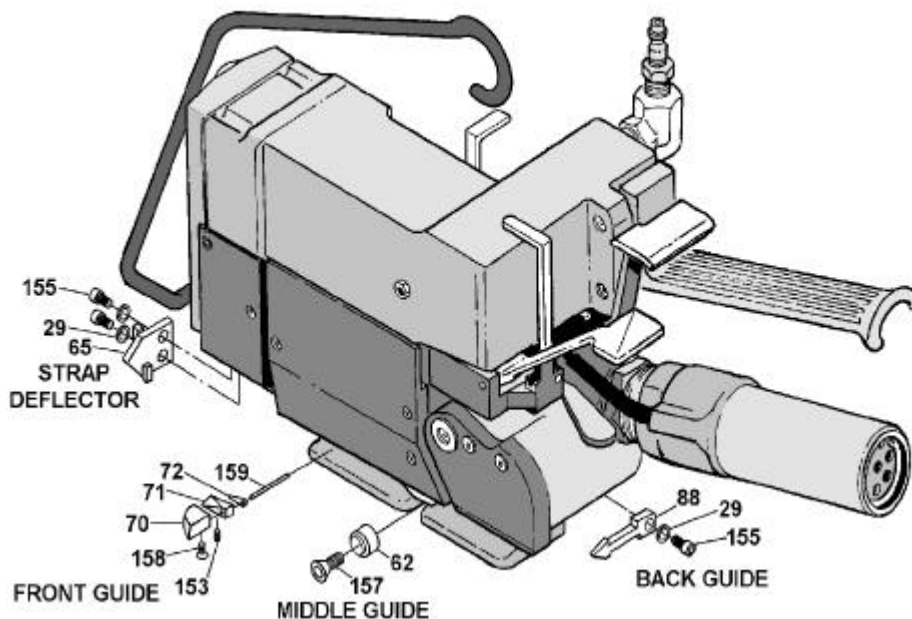

TOOL OPTIONS

WEAR PLATE, Part No. 423269

An optional wear plate can be installed on any PHT tool. This option is to protect the base plate from abuse from rough surfaces such as brick and block. The wear plate is secured to the tool using a standard fastener.

KEY	QTY	PART#	DESCRIPTION
29	1	187415	M5 SPLIT LOCKWASHER
155	1	028081	SHCS, M5 X 12
247	1	423269	WEAR PLATE

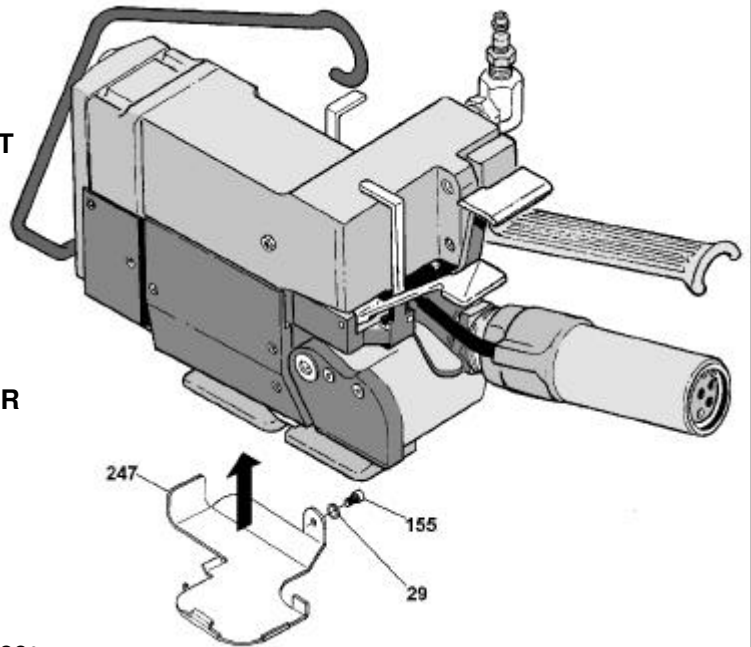

SWIVEL HANGER, Part No. 422760

The Swivel Hanger allows the PHT to be pivoted 360°. This feature allows the tool to strap horizontally around loads which do not have square sides. The force that is needed to rotate the tool can be adjusted by loosening or tightening the two hex nuts on the end of the pivot shaft. This hanger mounts to the front of the tool.

KEY	QTY	PART#	DESCRIPTION
1	1	422758	HANGER WELDMENT
2	3	422674	SPACER
3	1	422673	CAP
4	2	422761	PRESSURE PLATE ASSY
5	1	422677	WELDMENT MOUNTING PLATE
7	2	422763	BELLEVILLE WASHER, B1250-51
8	2	422759	HEX NUT, M10, LOW PROFILE
9	2	010072	SHCS, M5 X 50
10	1	186666	SHCS, M5 X 40
12	6	187416	SPLITLOCK WASHER

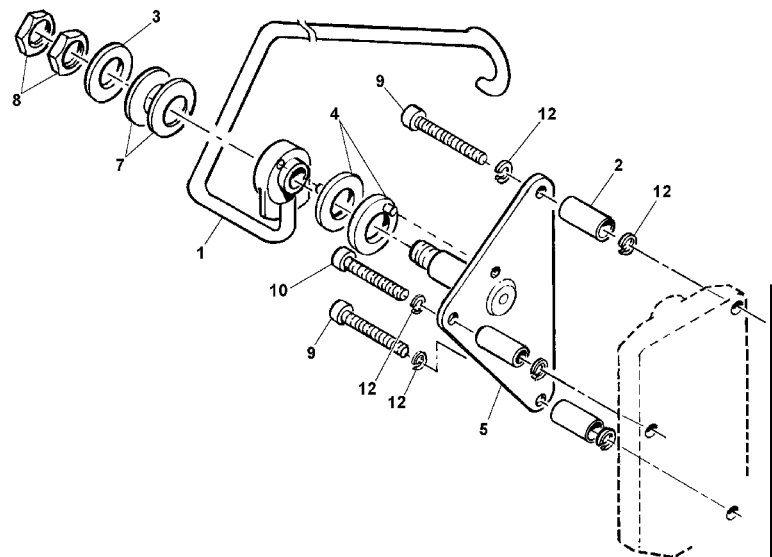
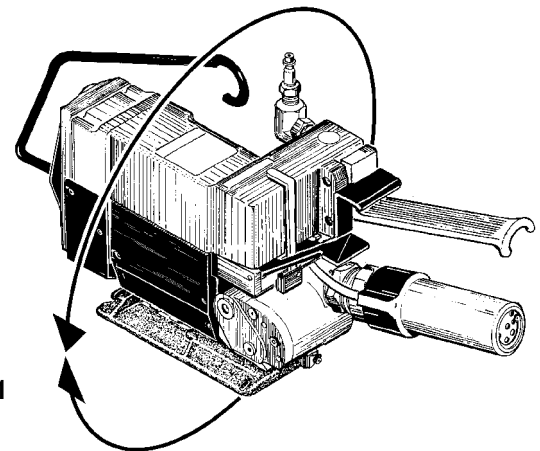

SIGNODE NEW TOOL WARRANTY

Signode Engineered Products Warrants that a new Signode strapping tool will operate per functional specifications for a period of sixty (60) days after the date of shipment to the owner's place of business. Normal wearing parts, as outlined in the Operation, Parts & Safety manual, are covered by a thirty (30) day warranty unless, in Signode's judgement, these parts have been subjected to abnormal or extreme usage. Signode's sole liability hereunder will be to repair or replace, without charge, F.O.B. Signode's Glenview, Illinois plant, any tool which proves to not operate per functional specifications within the stated period. Signode reserves the right to replace any tool which proves not to operate per functional specifications with a new or like-new tool of the same model if in Signode's judgement such replacement is appropriate. Any new replacement tool provided to an owner will carry a full sixty (60) day warranty. Any warranty repaired tool or like-new replacement tool will carry a warranty for the balance of the time remaining on the initial sixty (60) day warranty. This warranty will be extended to compensate for the time the tool is in Signode's possession for warranty repairs.

This warranty is void as to any tool which has been: (I) subjected to mis-use, misapplication, accident, damage, or repaired with other than genuine Signode replacement parts, (II) improperly maintained, or adjusted, or damaged in transit or handling; (III) used with improperly filtered, unlubricated air or improper strapping material, (IV) in Signode's opinion, altered or repaired in a way that affects or detracts from the performance of the tool.

SIGNODE MAKES NO WARRANTY, EXPRESSED OR IMPLIED, RELATING TO MERCHANTABILITY, FITNESS OR OTHERWISE EXCEPT AS STATED ABOVE AND SIGNODE'S LIABILITY AS ASSUMED ABOVE IS IN LIEU OF ALL OTHERS ARISING OUT OF OR IN CONNECTION WITH THE USE AND PERFORMANCE OF THE TOOL. IT IS EXPRESSLY UNDERSTOOD THAT SIGNODE SHALL IN NO EVENT BE LIABLE FOR ANY INDIRECT OR CONSEQUENTIAL DAMAGES INCLUDING, BUT NOT LIMITED TO, DAMAGES WHICH MAY ARISE FROM LOSS OF ANTICIPATED PROFITS OR PRODUCTION, SPOILAGE OF MATERIALS, INCREASED COSTS OF OPERATION OR OTHERWISE.

Considerable effort has been made to ensure that this product conforms to our high quality standards. However, should you experience any difficulties, please contact your Sales Representative providing samples and the manufacturing code specified on the tool.

Thank you for your help.

SIGNODE ENGINEERED PRODUCTS
Hand Tool Division
3620 W. Lake Avenue, Glenview, Illinois 60025

PART #	DESCRIPTION	AREA OF USE
LUBRICANTS		
177029	GEAR HOUSING GREASE	CLUTCH DRIVES, INTERNAL GEARS, GEAR SETS
422792	WHITE LUBRIPLATE GR-132 GREASE	PNEUMATIC PARTS, AIR CYLINDERS, AIR VALVES, O RINGS
422793	BLACK LUBRIPLATE 3000W GREASE	MOVING INTERNAL PARTS, JAWS, LINKS
432322	EP ACCROLUBE GREASE	HIGH FRICTION CONTACT PARTS
008556	LS-1236 AIR LINE OIL	AIR MOTORS, AIR VALVES
ADHESIVES		
422794	LOCTITE #222, PURPLE	LOW STRENGTH, SCREWS 1/4" (6MM) OR SMALLER SIZES
422795	LOCTITE #242, BLUE	MEDIUM STRENGTH, SCREWS 5/16" (8MM) OR LARGER SIZES
422796	LOCTITE #271, RED	HIGH STRENGTH, SEMI-PERMANENT SCREW APPLICATION
422797	LOCTITE #609, GREEN	PERMANENT, CURVED SURFACE PART CONTACT
274111	LOCTITE #380, BLACK MAX	PERMANENT, FLAT SURFACE PART CONTACT
CLEANING BRUSHES		
023963	SMALL BRUSH	FEEDWHEEL & GRIPPER TEETH
269589	LARGE BRUSH	FEEDWHEEL & GRIPPER TEETH