



READ ALL SAFETY INSTRUCTIONS BEFORE OPERATING THIS SIGNODE PRODUCT

OPERATION, PARTS AND SAFETY MANUAL

It is the customer's responsibility to have all operators and servicemen read and understand this manual.

ST-D TYPE STRAP TENSIONER

Part No. 257080

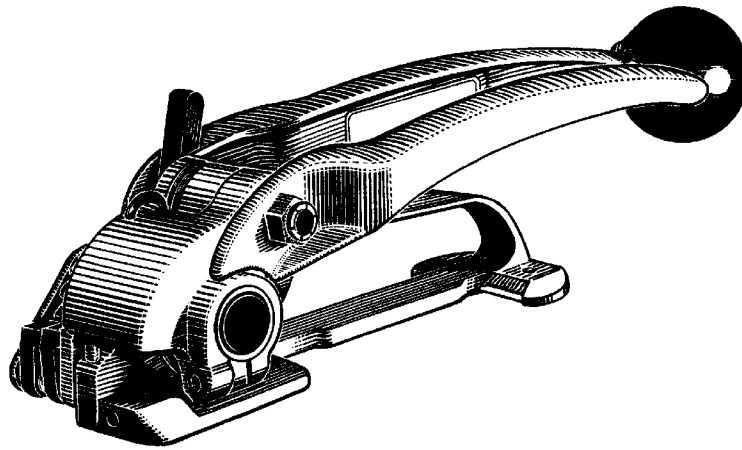

TOOL SPECIFICATIONS

STRAP TYPE	WIDTH	THICKNESS
Dymax, Contrax, Tenax	1/2" (12.7mm)	.015"(0.38mm) to .030"(0.76mm)

PLEASE NOTE:

Refer to Signode Operation, Parts & Safety Manual part number 186006 for additional part removal & replacement details and information.

IMPORTANT - DO NOT DESTROY THIS MANUAL. It is the customer's responsibility to have all operators and service personnel read and understand this manual. Contact your local Signode representative for additional copies of this manual.

SAFETY INSTRUCTIONS

**GENERAL SAFETY INSTRUCTIONS - READ THESE INSTRUCTIONS CAREFULLY.
FAILURE TO FOLLOW THESE INSTRUCTIONS CAN RESULT IN SEVERE PERSONAL INJURY.**

GENERAL CONSIDERATIONS

1. EYE INJURY HAZARD.

Failure to wear safety glasses with side shields can result in severe eye injury or blindness. Always wear safety glasses with side shields which conform to ANSI Standard Z87.1 or EN 166.



2. STRAP BREAKAGE HAZARD.

Improper operation of the tool or sharp corners on the load can result in strap breakage during tensioning, which could result in the following:



! A sudden loss of balance causing you to fall.

! Both tool and strap flying violently towards your face.

Failure to place the strap properly around the load or on an unstable or shifted load could result in a sudden loss of strap tension during tensioning. This could result in a sudden loss of balance causing you to fall.

Read the tools operating instructions. If the load corners are sharp use edge protectors. Place the strap correctly around a properly positioned load.

! Positioning yourself in-line with the strap, during tensioning and sealing, can result in severe personal injury from flying strap or tool. When tensioning or sealing, position yourself to one side of the strap and keep all bystanders away.

! Using strap not recommended for this tensioner can result in strap breakage during tensioning. Use the correct Signode products for your application.

3. FALL HAZARD.

Maintaining improper footing and/or balance when operating the tool can cause you to fall. Do not use the tool when you are in an awkward position.

4. CUT HAZARD

Always wear protective gloves when handling strap or sharp parts.



5. TRAINING.

This tool must not be used by persons not properly trained in its use. Be certain that you receive proper training from your employer. If you have any questions contact your Signode Representative.

6. TOOL CARE.

Take good care of the tool. Inspect and clean it daily, lubricate it weekly. Replace any worn or broken parts.

7. WORK AREA

Keep work areas uncluttered and well lit.

8. CUTTING TENSIONED STRAP

Using claw hammers, crowbars, chisels, axes or similar tools will cause tensioned strap to fly apart with hazardous force. Use only cutters designed for cutting strap. Read the instructions in the cutters manual for proper procedure in cutting strap. Before using any Signode product read its operation and safety manual.

Several combinations of strap, seals and tools can be used with this tensioner. Use the correct Signode products for your application. If you need help contact your Signode Representative.

SAFETY PROCEDURES FOR TOOL OPERATION

1. Before using this tensioner, read all the instructions in this Operation, Parts and Safety Manual.
2. NEVER HANDLE OR SHIP ANY LOAD WITH IMPROPERLY FORMED SEALS. Misformed seals may not secure the load and could cause serious injury. Inspect the tool for worn and/or damaged parts. Replace tool parts as needed.

If seals are not being properly formed:

- A. Ensure that the tool's operating instructions are being followed before applying another strap.
- B. Cut the strap off and apply another.

3. Tuck strap end back into the dispenser when not in use.

MAINTENANCE/CLEANING

Debris accumulated in the teeth of either the feedwheel or the clutch plug must be removed with a small wire brush. A need to clean the teeth will become apparent when either the feedwheel skids on the strap or the lower strap slips on the clutch plug during tensioning. Apply light machine oil to all moving parts.

OPERATING INSTRUCTIONS

⚠ WARNING

Wear safety glasses which conform to ANSI Standard Z87.1 or EN 166.

Always position yourself to one side of the strap while tensioning and sealing. Make sure all bystanders are clear before proceeding. Maintain proper footing and balance.

1. Drape strap around package. Take-up slack, keeping straps squarely in line. Hold hand tensioned strap in position with left hand, grasp the tool in right hand, squeeze handle to base, thus lifting feedwheel. Fully insert both straps between feedwheel and gripper plug, allowing lower strap to extend approximately 1" beyond gripper plug, as shown. Position rear foot of tool on top of straps.

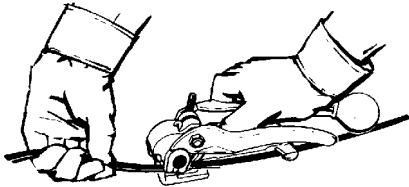

2. Stand to one side of the strap line. Tension is obtained through a continuous up and down motion with the tensioning handle. At the same time, maintain a constant upward pressure on the reaction handle, lifting the back of the base slightly off the package. On initial downward strokes, do not allow handle to press against base as this will raise feedwheel and release tensioned strap. Snap seal on strap directly in front of tool.

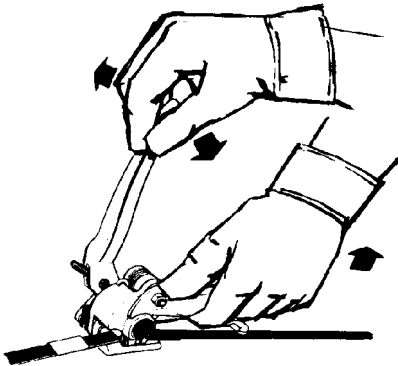

3. Hold sealing tool at right angles to strap, resting it squarely over seal. Seal the tensioned strap by bringing sealer handles together as far as they will go.

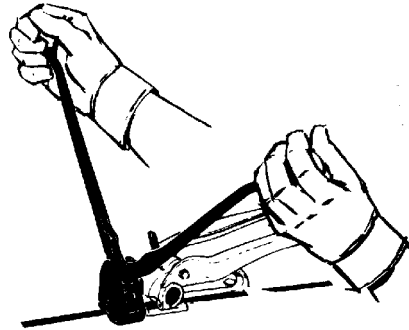

4. Return tensioning handle to rest on the tool by pressing the handle pawl with thumb. Squeeze handle to base and remove tool from strap by swinging rear foot out, as illustrated.

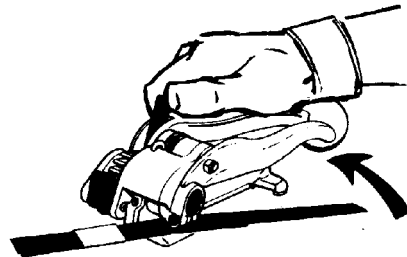

5. With left hand, pull top strap back and at an angle to the left, holding taut. Place base of tool just ahead of seal, cutter blade on the strap. Grasp knob of tensioning handle and slide tool forward to cut the strap. Inspect the joint to make sure it had been properly formed. Refer to the sealing tool manual for details regarding the joint.

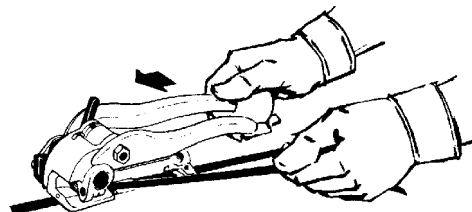

ST-D TENSIONER PARTS LIST

KEY	QTY.	PART #	DESCRIPTION
1	1	003489	Handle pawl spring
2	1	003492	Handle pawl
3	1	003493	Handle
5	1	003488	Ratchet gear
6	1	003494	Handle pawl pin
7	1	023964	Feedwheel support pin
8	1	003490	Feedwheel support
9	1	023954	Feedwheel
10	1	003485	Short retaining pawl
11	2	003483	Retaining pawl spring
12	1	003484	Long retaining pawl
13	1	003486	Retaining pawl pin
14	1	004502	SHCS, #10-32 x 3/4
15	1	023953	Reaction handle
16	1	003868	Flexloc thin nut, -24
17	1	003487	Feedwheel shaft
18	1	003478	Bearing
19	1	003479	Feedwheel spring
20	1	023957	Set screw, #10-32 x
21	1	023965	Set screw, #10-32 x
22	1	020711	Truarc, #5101-37
23	1	023912	Gripper plug
24	1	023966	Cutter blade
25*	1	023967	FHSS, #10-32 x 5/16
26	1	023952	Base
27	1	183024	Nameplate
28	1	182997	Caution plate
29	1	098228	Protective cover
30	1	003133	Caution plate
31	1	003493	Handle
32	1	306927	Knob
33	1	010057	Roll pin, 1/4D x 1-3/4LG
34	1	424250	Bushing
35	1	424251	BHCS, 1/4-28 x 1/4
--	1	023963	Brush

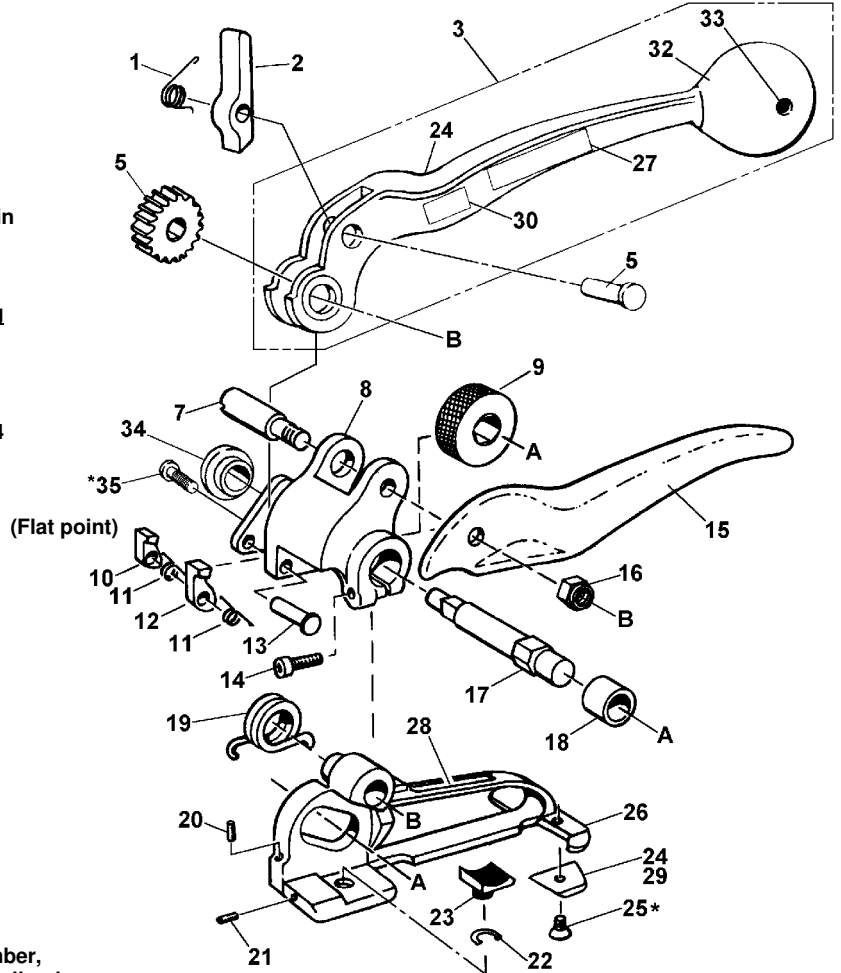

When ordering parts, please show tool model, part number, and description. All recommended spare parts are underlined and should be stocked.

* Apply one drop of Loctite #271 (Red) or equivalent, available as Signode Part No. 422796.

NOTE: Keys numbers 8, 34 and 35 can be ordered together as Gear Housing Kit, Signode part No. 424436.

WARNING All parts must be periodically inspected and replaced if worn or broken. Failure to do this can affect a product's operation and can result in personal injury.

CLUTCH PLUG ADJUSTMENT

- Maintain a clearance of .001 to .005 between the feed wheel (9) and the gripper plug (23) by adjusting the set screw (21) as needed. See page 9 for the set screw location on the tool.

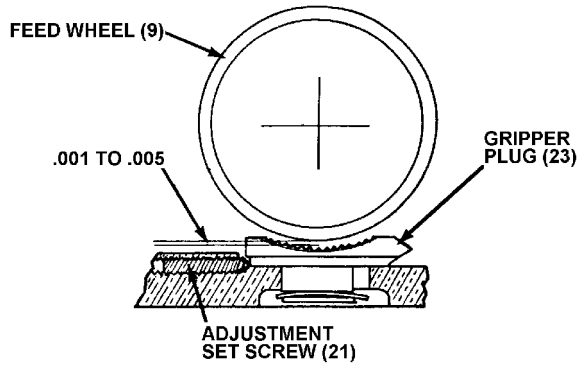

- Depress the handle (3) to raise the feed wheel support assembly (8).

- While the support assembly is raised, turn in the set screw (21) clockwise, until it bottoms out.
- Back out the set screw (21) 1 3/4 turns for a general factory setting. If needed, continue to back out or turn in the set screw according to the following chart of strap variations. General factory setting is 1 3/4 turns.

STRAP	NO. OF TURNS
502, 504	1 1/2
506	1 3/4
508	2 1/2
1816	1 3/4
1822	2 1/2
814	1 1/2
816, 818	1 3/4

NOTE: As the tool wears, it may be necessary to turn the set screw (21) in 1/4 to 1/2 turn. This will become apparent if strap begins to slip in the tool while under tension.