

MODEL P714

Semi-Automatic Strapping Machine



Features

- Electronic Seal Head Design
- Fast and Quiet Operation
- Electronic Tension Control
- Unique Dual Tension Mode
- 45 Second Warm Up
- Fewer Moving Parts
- Reinforced Table Supports
- Portable, Locking Casters
- 110 Volt Electrical

Model P714

Semi-Automatic Strapping Machine

Product Features

The P714 is a value packed semi automatic strapping machine with features found on more expensive machines.

The strap cycle is fast and quiet.

The all electric seal engine has fewer moving parts than others and will provide consistent tension and seal results with less maintenance.

The unique dual tension system can be set for either a slow gentle pull or for a standard fast tensioning cycle.

This portable lightweight strapping machine is reinforced at the table top to support heavy packages without trouble.

Specifications

Min. Bundle Dimensions	W 4" x H 1 ¼"
Maximum Package Weight	80 lbs
Tensioning Range	Up to 88 lbs
Strapping Used	¼, ⅜, ½, ⅝"
Power Supply	110 Volt Single Phase
Machine Dimensions	W 30 ¾" x H 30 ½" x D 21 ½"
Table Height	29 ½"
Machine Weight	110 lbs
Shipping Weight	140 lbs

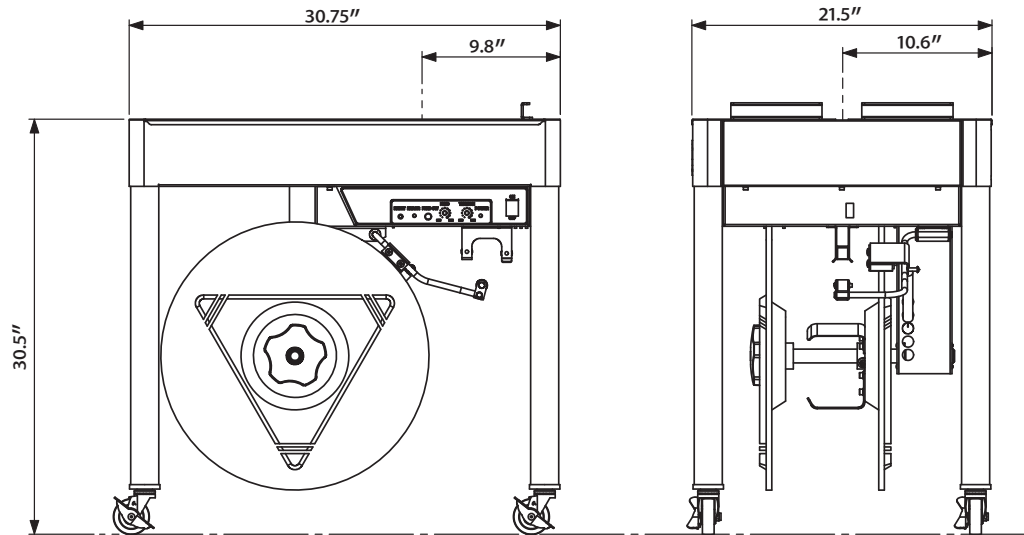

Distributed By: