

## MODEL P703VLM

### HIGH TENSION STRAPPING MACHINE

---

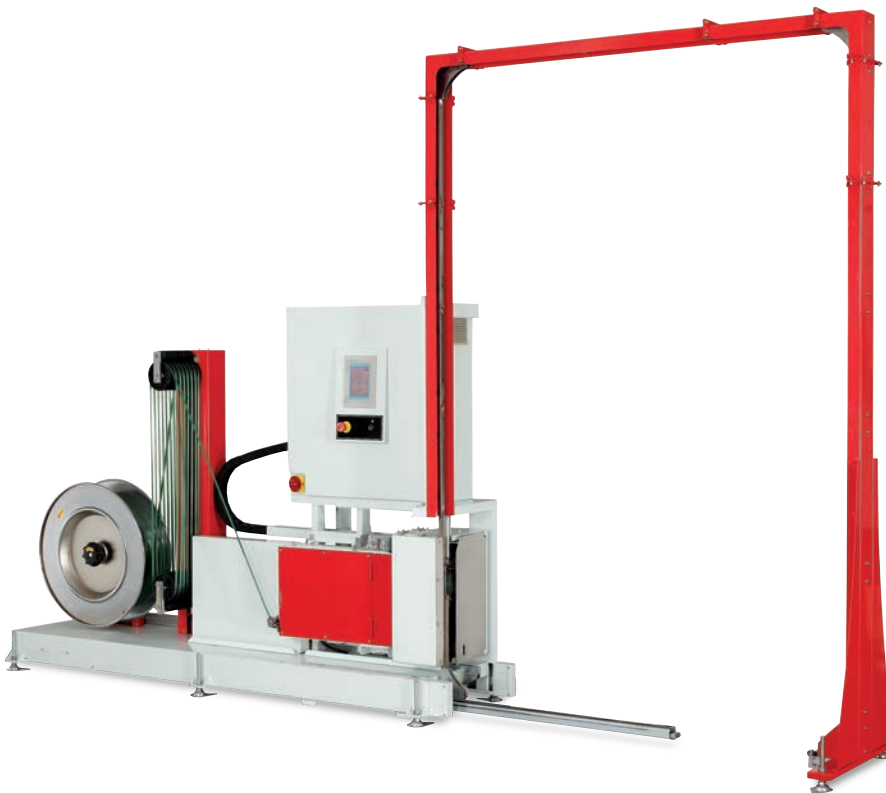

## Features

- Heavy Duty Friction Seal Strapping Head
- Polyester or Polypropylene Strapping
- Indexing Head and Void Bayonet Systems
- Siemens PLC Control and HMI
- The Siemens PLC control and HMI (touch panel) provide easy adjustment and troubleshooting.
- Easy TEACH-IN programming.
- Can be automated with Powered Conveyors
- 55" Wide x 96" High Arch Shown
- Other Sizes available

## Options

- Floating head
- Free standing operator station
- Conveyors

- **P703V:** Closed strap track, fixed strapping head
- **P703VM:** Closed strap track, indexing strapping head
- **P703VLM:** With bayonet, indexing strapping head

# MODEL P703VLM

## HIGH TENSION STRAPPING MACHINE

### Standard Features

The Samuel P703V Strapping Machine offers high tension and heavy duty industrial frame design for heavy pallet strapping applications.

Easy to operate controls with the PLC and HMI touch screen interface.

Can be used with smooth or embossed polyester and polypropylene strapping. Sealing time and cooling time are adjustable to assure reliable seal efficiency.

Whether you need a conveyORIZED system, or a stand-alone machine to apply high strength strapping, the P703 series can help solve the most demanding projects.

### Specifications

Joint/Strap	Friction Seal/ Polyester or Polypropylene Strapping
Strap Width	9, 12, 15 mm $\frac{3}{8}, \frac{1}{2}, \frac{5}{8}$ "
Speed	10 Second Cycle Speed
Tension	Up to 660 pounds
Power Supply	480 Volt, 3 phase Electrical

*Dimensions and specifications are subject to change without notice.*

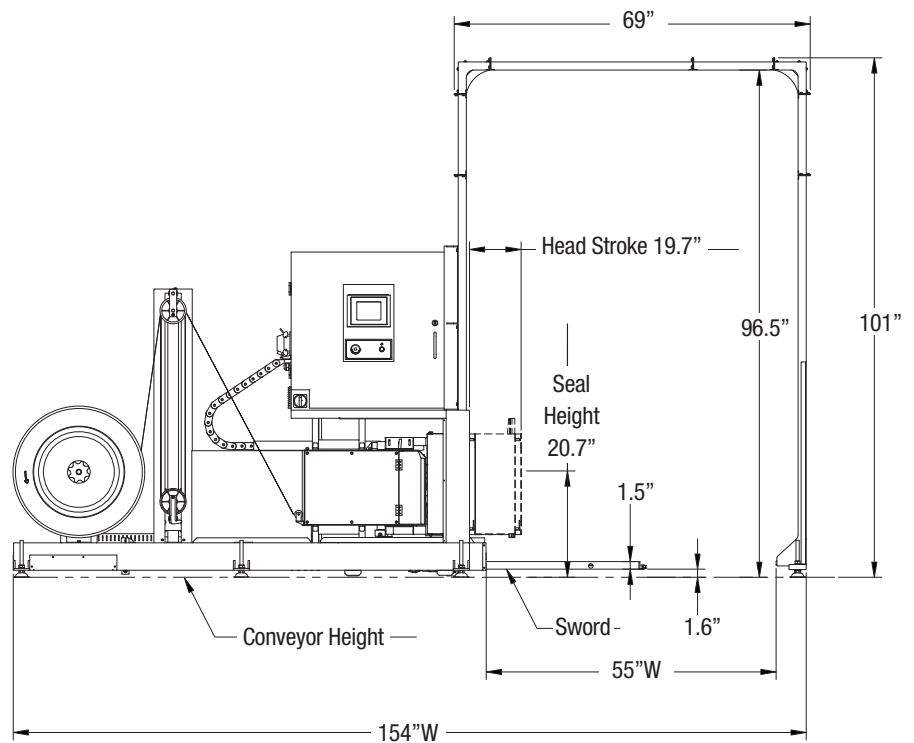
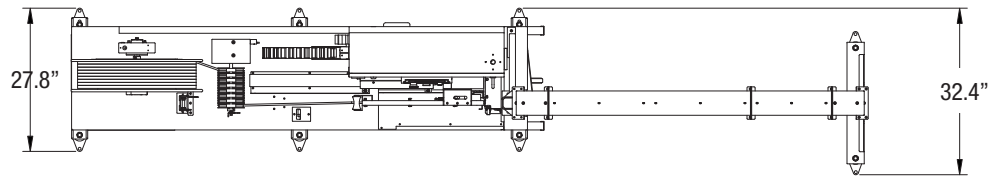

P703VLM-09/14-110064