

MODEL P702BS

Fully Automatic Conveyorized Stainless Steel Strapping Machine

Features

Up to 40 Packages per Minute in Single Strap Mode

Cycle Speed Up To 65 Straps per Minute

Operates with 5mm, 6mm, 9mm or 12mm Polypropylene Strapping

Single, Double, Multiple Strap and Bypass Modes

High Performance DC Brushless Motor Technology

Precision Electronic Tension

Automatic Strap Loading

End of Coil Strap Ejector

Loop Ejector

Anti Jam Technology

Hinged Conveyor Frames for Easy Access

Fully Automatic Operation with Photo Eyes

Variable Conveyor Speed



Model P702BS

Fully Automatic Conveyorized Stainless Steel Strapping Machine

Product Features

The Samuel Model P702BS Fully Automatic Strapping Machine features high operating speeds combined with heavy duty structural designs to use in the most demanding applications. The P702BS also features a stainless steel frame, body and covers for use in cold, wet environments.

The operator control panel offers easy access to any machine function and includes an LCD display showing machine operation status and maintenance diagnostics

The P702BS may be the most operator friendly strapping machine in its class. It features automatic strap loading, automatic strap ejector when the coil runs out and loop ejector when cycled without a package present.

The heavy duty wide belt conveyor design is hinged for easy access to the seal engine when needed. A safety switch is included to cut electrical power when opened, and restore power again when closed.

Specifications

Strapping Speed	Up to 40 Packages per Minute Cycles Up To 65 Straps per Minute
Minimum Package Size	4.75" Wide x 1" Height x 5" Length
Maximum Package Size	Arch Width x Arch Height
Maximum Package Weight	100 Pounds
Strapping Width Set Up	5mm, 6mm, 9mm, 12mm (8x8 Core)
Table Height	31.5" to 35.4" Adjustable Optional 29.5" to 35.4" Adjustable
Tensioning Range	Up to 115 Pounds of Tension
Power Supply	110 Volt (220,230) 1 Phase Optional 220, 480 Volt 3 Phase
Machine Weight	500 Pounds
Shipping Weight	575 Pounds
Machine Dimensions (Shown for 25" x 19" Arch Size)	55" W x 25.6" L x 55" H

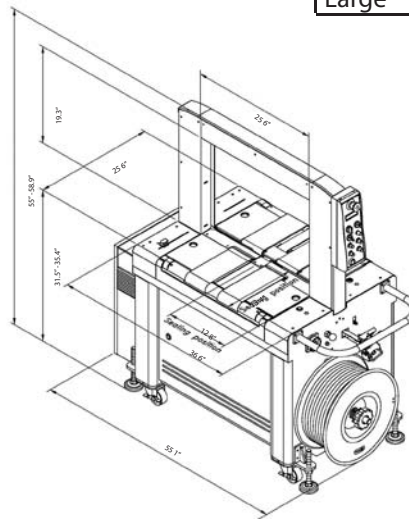

Available Options

- Siemens PLC Control
- Low Adjustable height
- 3 Phase Electrical
- Triple Lamp Light Tree With Low Strap Sensor
- Energy Saving Conveyor Sleep Mode Function
- Centered Strapping
- Press Assembly (P702BPS)

Standard Arch Sizes

	Width	Height
Standard	25"	19"
Large	33"	23"

Distributed By:



Optional Press Assembly



Master Controls

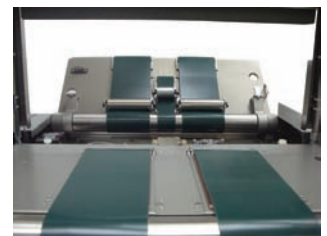

Easy Access Hinged Conveyors